

# User Manual



GP8300 / GP8300TX / GP6300 / GP6300TX / GP2700

HVBAN®

## Gas-Mechanical Airless Sprayer

- For Portable Airless Spraying of Architectural Coatings and Paints
- 3336 psi (23 MPa, 230 bar) Maximum Working Pressure





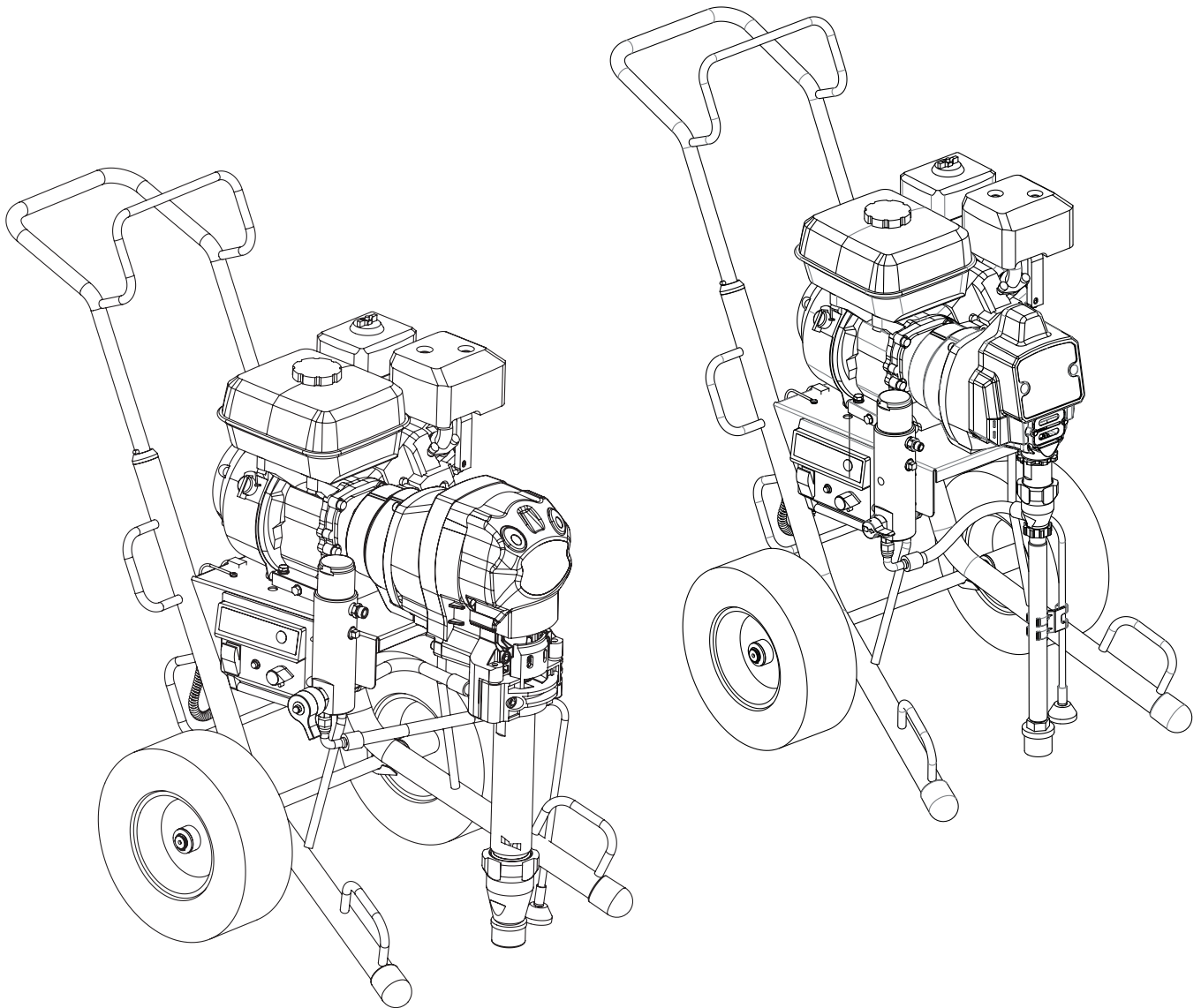









**Important Safety Instructions.** Read all warnings and instructions in this manual. Save these instructions.



# Warning

The following warnings include general safety information for this equipment. Further product specific warnings may be included in the text where applicable.

 <b>WARNING</b>	
	<p><b>FIRE AND EXPLOSION HAZARD</b></p> <p>Flammable fumes, such as solvent and paint fumes, in work area can ignite or explode. To help prevent fire and explosion:</p> <ul style="list-style-type: none"> <li>• Use equipment only in well ventilated area.</li> <li>• Do not fill fuel tank while engine is running or hot; shut off engine and let it cool. Fuel is flammable and can ignite or explode if spilled on hot surface.</li> <li>• Eliminate all ignition sources; such as pilot lights, cigarettes, portable electric lamps, and plastic drop cloths (potential static arc).</li> <li>• Keep work area free of debris, including solvent, rags and gasoline.</li> <li>• Do not plug or unplug power cords, or turn power or light switches on or off when flammable fumes are present.</li> <li>• Ground equipment and conductive objects in work area. See Grounding instructions.</li> <li>• Use only grounded hoses.</li> <li>• Hold gun firmly to side of grounded pail when triggering into pail.</li> </ul> <p>If there is static sparking or you feel a shock, stop operation immediately.</p> <ul style="list-style-type: none"> <li>• Do not use equipment until you identify and correct the problem.</li> <li>• Keep a fire extinguisher in the work area.</li> </ul>
	<p><b>INJECTION HAZARD</b></p> <p>High-pressure fluid from gun, hose leaks, or ruptured components will pierce skin. This may look like just a cut, but it is a serious injury that can result in amputation. Get immediate surgical treatment.</p> <ul style="list-style-type: none"> <li>• Do not point gun at anyone or at any part of the body.</li> <li>• Do not put your hand over the spray tip.</li> <li>• Do not stop or deflect leaks with your hand, body, glove, or rag.</li> <li>• Do not spray without tip guard and trigger guard installed.</li> <li>• Engage trigger lock when not spraying.</li> <li>• Follow Pressure Relief Procedure in this manual, when you stop spraying and before cleaning, checking, or servicing equipment.</li> <li>• Check everyday for the wearing of hose and connector, if need replace them.</li> <li>• Screw tight all the connector parts before spraying.</li> </ul>
	<p><b>MOVING PARTS HAZARD</b></p> <p>Moving parts can pinch or amputate fingers and other body parts.</p> <ul style="list-style-type: none"> <li>• Keep clear of moving parts.</li> <li>• Do not operate equipment with protective guards or covers removed.</li> <li>• Pressurized equipment can start without warning. Before checking, moving, or servicing equipment, follow the Pressure Relief Procedure in this manual. Disconnect power or air supply.</li> </ul>
	<p><b>PRESSURIZED EQUIPMENT HAZARD</b></p> <p>Fluid from the gun/dispense valve, leaks, or ruptured components can splash in the eyes or on skin and cause serious injury.</p> <ul style="list-style-type: none"> <li>• Follow Pressure Relief Procedure in this manual, when you stop spraying and before cleaning, checking, or servicing equipment.</li> <li>• Tighten all fluid connections before operating the equipment.</li> <li>• Check hoses, tubes, and couplings daily. Replace worn or damaged parts immediately.</li> </ul>

 <b>WARNING</b>	
	<p><b>PRESSURIZED ALUMINUM PARTS HAZARD</b></p> <p>Do not use 1,1,1-trichloroethane, methylene chloride, other halogenated hydrocarbon solvents or fluids containing such solvents in pressurized aluminum equipment. Such use can cause serious chemical reaction and equipment rupture, and result in death, serious injury, and property damage.</p>
	<p><b>SUCTION HAZARD</b></p> <p>Never place hands near the pump fluid inlet when pump is operating or pressurized. Powerful suction could cause serious injury.</p>
	<p><b>CARBON MONOXIDE HAZARD</b></p> <p>Exhaust contains poisonous carbon monoxide, which is colorless and odorless. Breathing carbon monoxide can cause death. Do not operate in an enclosed area.</p>
	<p><b>TOXIC FLUID OR FUMES HAZARD</b></p> <p>Toxic fluids or fumes can cause serious injury or death if splashed in the eyes or on skin, inhaled, or swallowed.</p> <ul style="list-style-type: none"> <li>• Read MSDS's to know the specific hazards of the fluids you are using.</li> <li>• Store hazardous fluid in approved containers, and dispose of it according to applicable guidelines.</li> </ul>
	<p><b>BURN HAZARD</b></p> <p>Equipment surfaces and fluid that's heated can become very hot during operation. To avoid severe burns, do not touch hot fluid or equipment. Wait until equipment/fluid has cooled completely.</p>
	<p><b>PERSONAL PROTECTIVE EQUIPMENT</b></p> <p>You must wear appropriate protective equipment when operating, servicing, or when in the operating area of the equipment to help protect you from serious injury, including eye injury, inhalation of toxic fumes, burns, and hearing loss. This equipment includes but is not limited to:</p> <ul style="list-style-type: none"> <li>• Protective eyewear</li> <li>• Clothing and respirator as recommended by the fluid and solvent manufacturer</li> <li>• Gloves</li> <li>• Hearing protection</li> </ul>
	<p><b>EQUIPMENT MISUSE HAZARD</b></p> <p>Misuse can cause death or serious injury.</p> <ul style="list-style-type: none"> <li>• Do not exceed the maximum working pressure or temperature rating of the lowest rated system component. See Technical Data in all equipment manuals.</li> <li>• Use fluids and solvents that are compatible with equipment wetted parts. See Technical Data in all equipment manuals. Read fluid and solvent manufacturer's warnings.</li> <li>• Check equipment daily. Repair or replace worn or damaged parts immediately.</li> <li>• Do not alter or modify equipment.</li> <li>• For professional use only.</li> <li>• Use equipment only for its intended purpose.</li> <li>• Route hoses and cables away from traffic areas, sharp edges, moving parts, and hot surfaces.</li> <li>• Do not use hoses to pull equipment.</li> <li>• Comply with all applicable safety regulations.</li> </ul>

# Component Identification (GP8300 / GP8300TX)

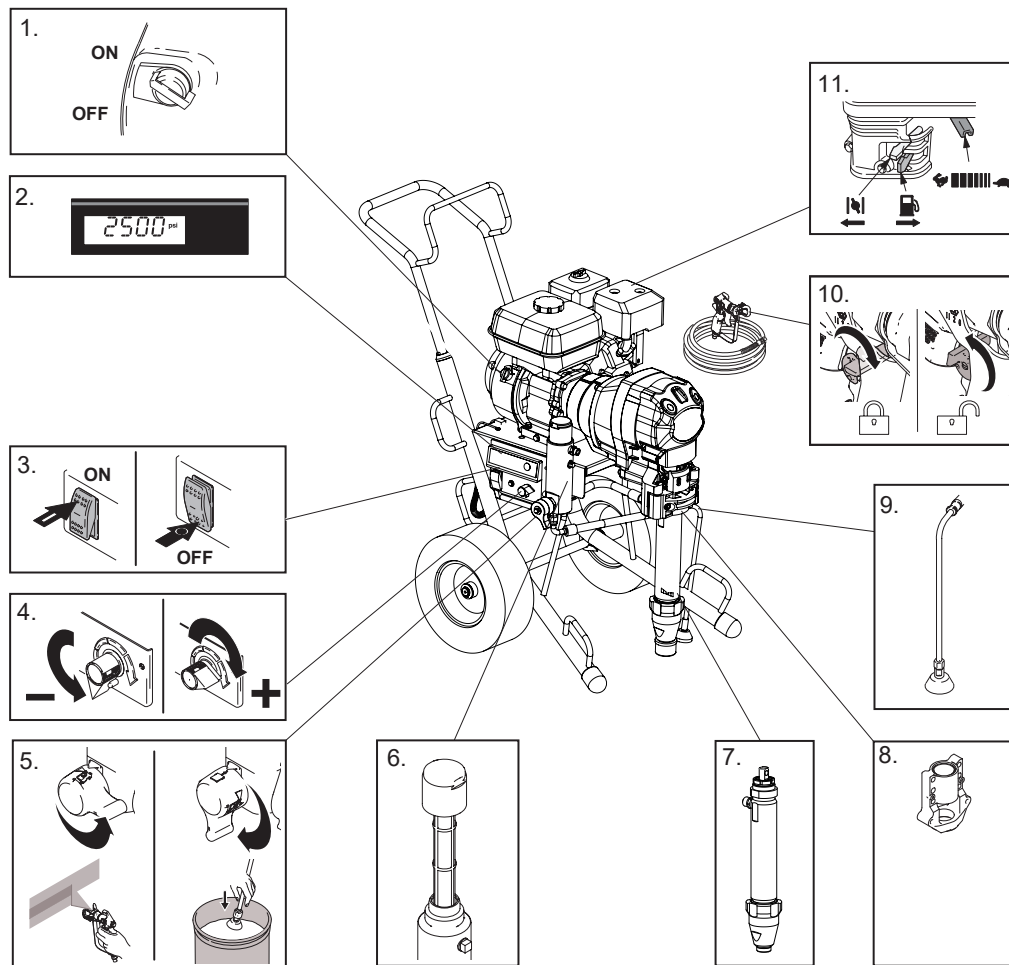

1	Engine ON/OFF switch
2	Premium Digital Display
3	Pump ON/OFF Switch
4	Pressure Control
5	Prime Valve
6	Manifold
7	Pump
8	Housing
9	Drain Hose
10	Trigger Lock
11	Engine Controls

# Component Identification (GP2700 / GP6300 / GP6300TX)

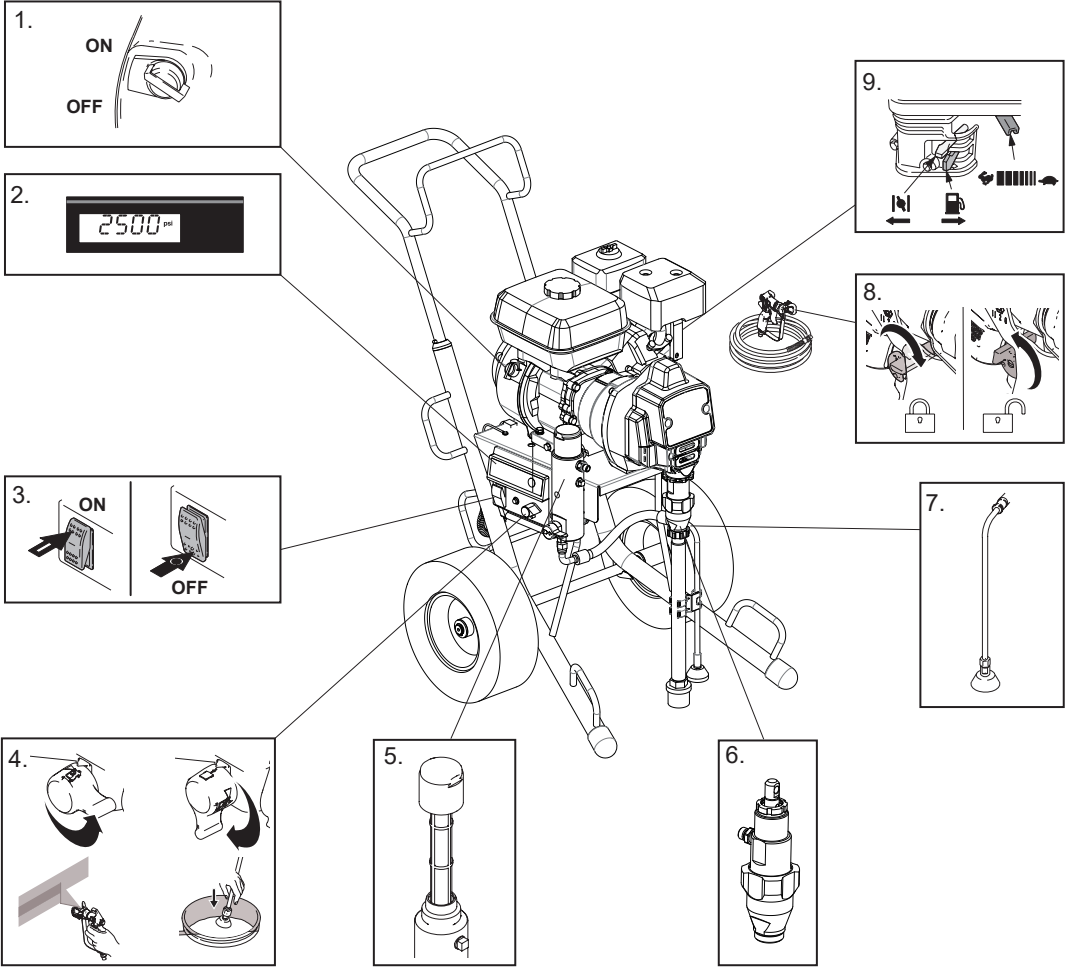

1	Engine ON/OFF switch
2	Premium Digital Display
3	Pump ON/OFF Switch
4	Prime Valve
5	Manifold
6	Pump
7	Drain Hose
8	Trigger Lock
9	Engine Controls

## Pressure Relief Procedure



1. Lock gun trigger safety.



2. Turn engine ON/OFF switch to OFF.



3. Move pump switch to OFF.

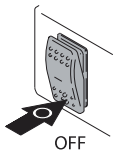

4. Unlock gun trigger safety. Turn pressure to lowest setting. Trigger gun into pail to relief pressure.

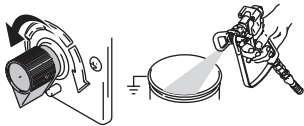

## Setup/Installation



1. Connect high-pressure hose to sprayer.  
Tighten securely

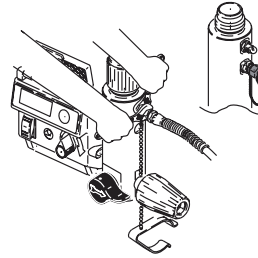

2. Install adapter and 1.5m whip hose to other end of high pressure hose.



3. Install whip hose to fluid inlet of spray gun.

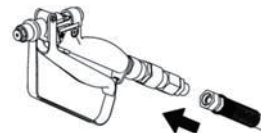

4. Tighten securely.

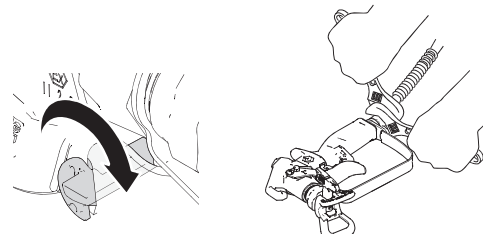

5.Remove tip guard

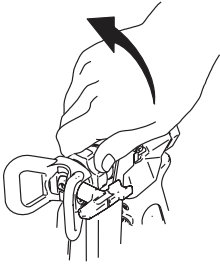

6.Unlock trigger safety. Hold metal part of gun firmly to side of grounded metal pail, and trigger gun to relieve pressure.

7.Lock gun trigger safety.

8.Open pressure drain valve. Leave valve open until ready to spray again.

If you suspect that the spray tip or hose is completely clogged, or that pressure has not been fully relieved after following the steps above, VERY SLOWLY loosen tip guard retaining nut or hose end coupling to relieve pressure gradually, then loosen completely. Now clear tip or hose.

9.Remove inlet bowl screen when spraying plaster materials.

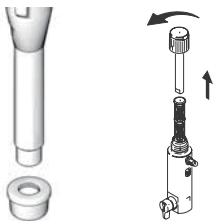

10.Fill throat packing nut with TSL to prevent premature packing wear. Do this each time you spray.

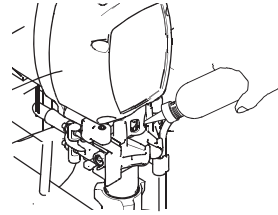

11.Check engine oil level. Add SAE 10W-30 (summer) or 5W-20 (winter), if necessary.



12.Fill fuel tank.

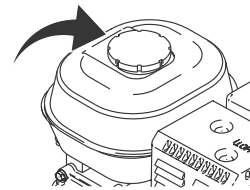

13.Attach sprayer grounding clamp to earth ground.

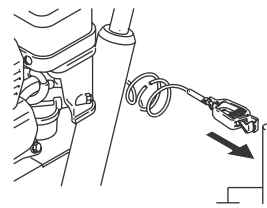

# Startup

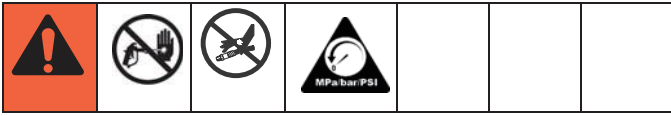

1. Place suction tube and drain tube in grounded metal pail partially filled with flushing fluid. Attach ground wire to pail and to earth ground.

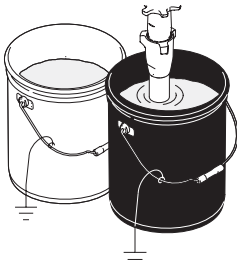

2. Turn prime valve down. Turn pressure control counterclockwise to lowest pressure.

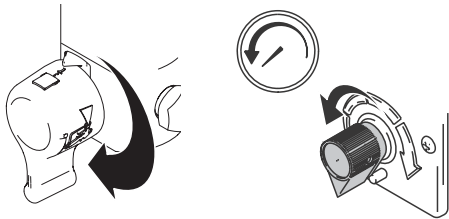

3. Set pump switch OFF.

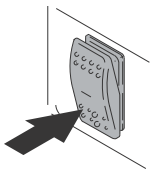

4. Start engine

a. Move fuel valve to open.      b. Move choke to closed.

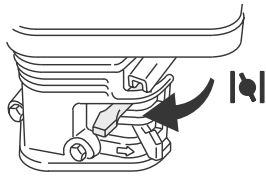

c. Set throttle to fast.

d. Set engine switch to ON.

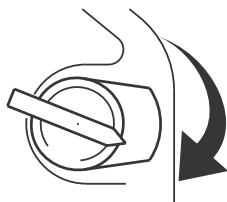
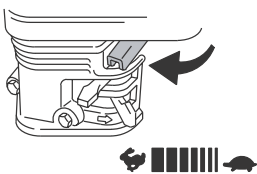

e. Pull starter rope.

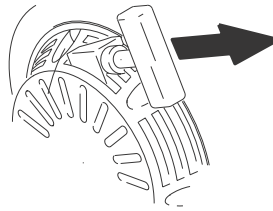

f. After engine starts, move choke to open.

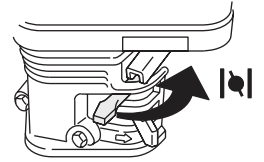

g. Set throttle to desired setting.

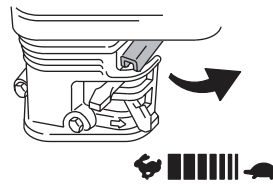

5. Set pump switch ON.

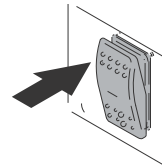

6. Increase pressure enough to start pump stroking and allow fluid to circulate for 30 seconds; turn pressure down and turn prime valve horizontal.

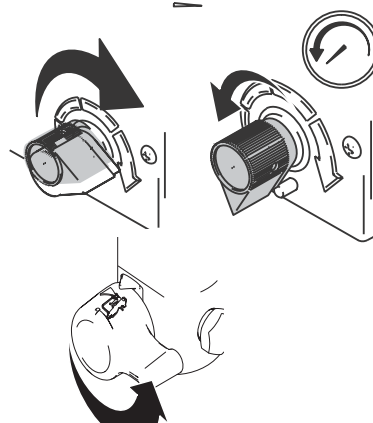

7. Take spray gun trigger safety OFF.



8. Hold gun against grounded metal flushing pail. Trigger gun and increase fluid pressure slowly until pump runs smoothly.

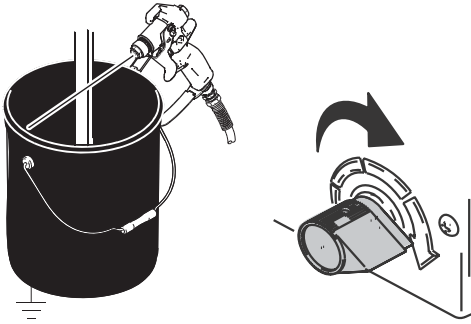

Inspect fittings for leaks. Do not stop leaks with your hand or a rag! If leaks occur, turn sprayer OFF immediately. Perform Pressure Relief steps 1 - 3 on page 4 Tighten leaky fittings. Repeat Start Up procedure steps 1 - 5. If no leaks, continue to trigger gun until system is thoroughly flushed. Proceed to step 6.

9. Place siphon tube in material pail.

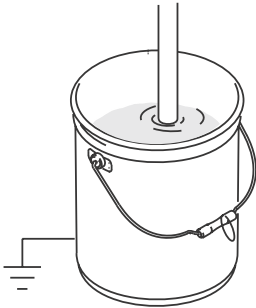

10. Trigger gun again into flushing fluid pail until material appears.

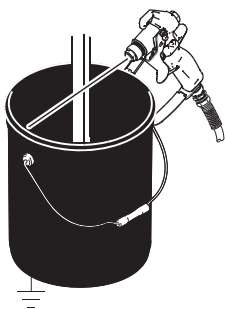

## Tip and Tip Guard



1. Insert gasket and seal to tip guard

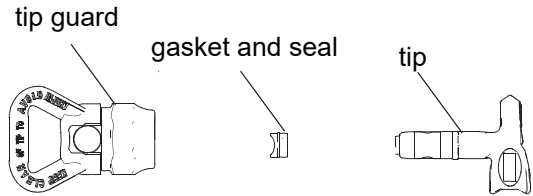

2. Insert SwitchTip.

3. Screw assembly onto gun. Tighten.

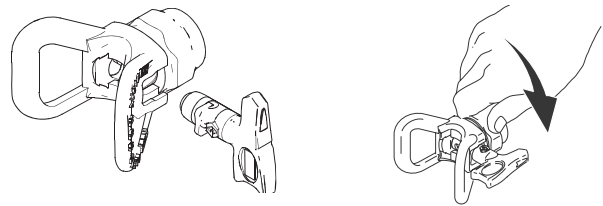

## Spray

1. Trigger gun and spray test pattern. Slowly adjust pressure to eliminate heavy edges. Use smaller tip size if pressure adjustment can not eliminate heavy edges.

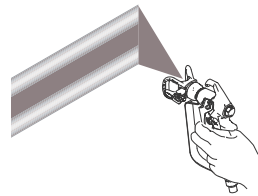

2. Hold gun perpendicular, 10-12 in. (25-30 cm) from surface. Spray back and forth. Use strokes overlapped by 50%. Start gun movement before triggering gun and release trigger before stopping gun movement.

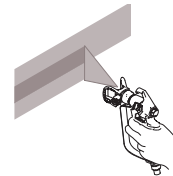

## Clearing Tip Clogs

1. Release trigger, put trigger safety ON. Rotate SwitchTip. Take trigger safety OFF and trigger gun to clear the clog.

2. Put trigger safety ON, return SwitchTip to original position, take trigger safety OFF and continue spraying.

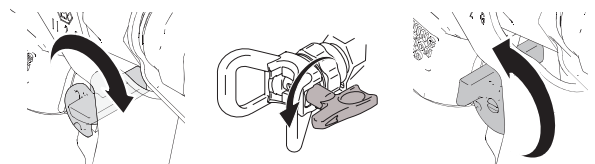
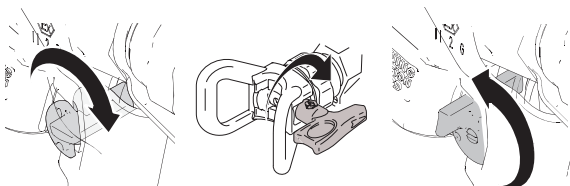

# Cleanup

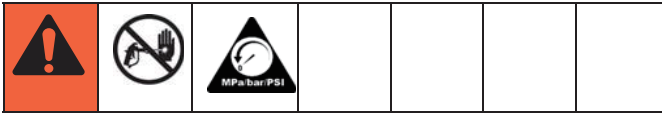

1. Do pressure relief procedure as page 4. Remove guard and SwitchTip. Remove siphon tube set from material and place in flushing fluid.

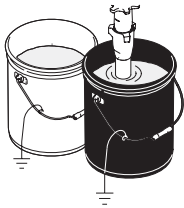

Noted: Use water for water base material and appropriate solvent for oil base material.

2. Turn engine on, set power on, turn prime valve horizontal.

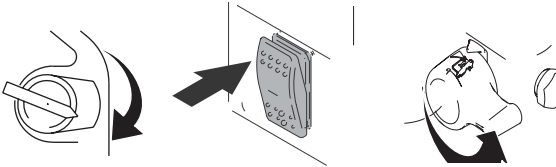

3. Adjust pressure control to 1/2 position. Hold gun against material pail. Take trigger safety OFF. Turn pressure control up until motor begins to drive pump. Trigger gun until flushing fluid appears.

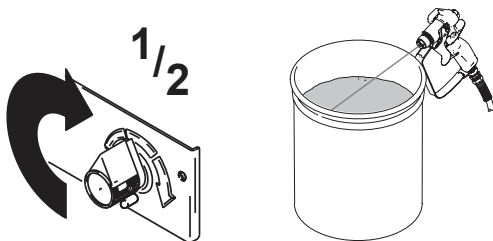

4. Move gun to wastepail, hold gun against pail, trigger gun to thoroughly flush system. Release trigger and put trigger safety ON.

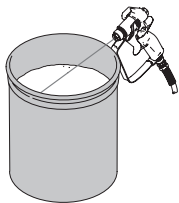

5. Turn prime valve down and allow flushing fluid to circulate for approximately 30 seconds to clean drain tube.

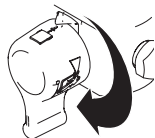

6. Raise siphon tube above flushing fluid and run sprayer for 15 to 30 seconds to drain fluid. Turn pump switch OFF. Turn engine OFF.

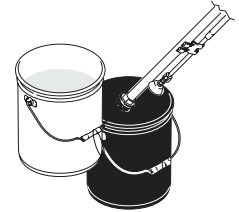

7. Close drain valve. Trigger gun into flushing pail to purge fluid from hose.

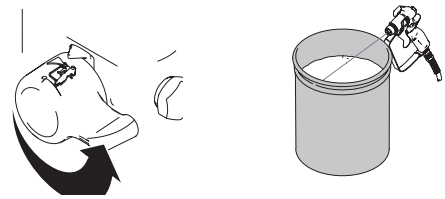

8. Open prime valve. Turn power off, turn off engine switch.

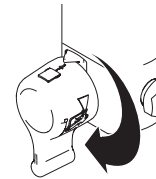

9. Unscrew bowl, remove filter. Clean filter. Do after every work.



10. If flushing with water, flush again with mineral spirits, or Pump Armor, to leave a protective coating to prevent freezing or corrosion.

11. Wipe sprayer, hose and gun with a rag soaked in water or mineral spirits.



## Flushing Recommendations

If you are going to:	Flush with:	Prime with:	Clean with:	Store with:
Spray with new sprayer or sprayer that has been stored	Compatible solvent such as water or mineral spirits	Compatible paint, such as water-base or oil-base	Compatible solvents such as water or mineral spirits	Mineral spirits
Spray water-base paint	Warm, soapy water, then clean water	Water-base paint	Warm, soapy water, then clean water	Mineral spirits
Spray oil-base paint	Mineral spirits	Oil-base paint	Mineral spirits	Mineral spirits
Change water-base to oil-base paint	Warm, soapy water, then clean water	Mineral spirits	Mineral spirits	Mineral spirits
Change oil-base to water-base paint	Mineral spirits, soapy water, then clean water	Water-base paint	Warm, soapy water, then clean water	Mineral spirits
Change colors, same base	Compatible solvent such as water or mineral spirits			

## Technical Data

Model	Sprayer Type	Power Type	Dynamic Power	Flow Delivery	Working Pressure	Max.Nozzle Size
GP2700	Project	Honda Gasoline Engine	3600W / 4.8HP	2.7 L/min	23 Mpa / 3336 psi	0.025"
GP6300 / GP6300TX	Project	Honda Gasoline Engine	3600W / 4.8HP	5.0 L/min	23 Mpa / 3336 psi	1 gun with 0.033" / 2 guns with 0.027"
GP8300 / GP8300TX	Project	Honda Gasoline Engine	4900W / 6.5HP	8.3 L/min	23 Mpa / 3336 psi	1 gun with 0.047" / 2 guns with 0.033"

GP8300 / GP8300TX

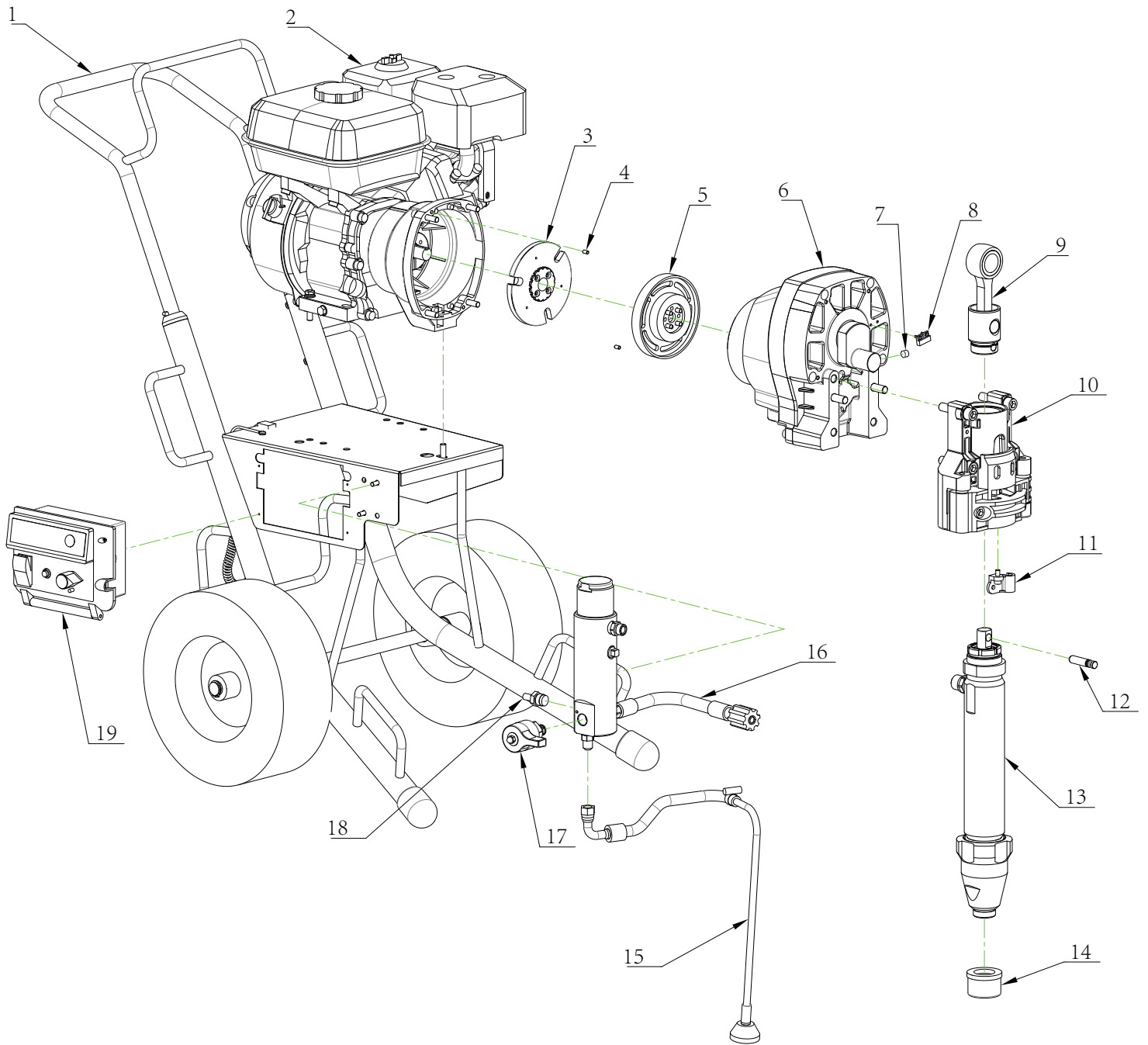

NO	DISCRIPTION	QTY
1	Rack Assembly	1
2	GX200 Engine Assembly	1
3	Clutch Disc	1
4	Pin	2
5	Clutch Disc	1
6	Drive Housing Assembly	1
7	Magnet	1
8	Inductor	1
9	Piston Rod	1
10	Bearing Housing	1
11	Hook	1
12	Pin	1
13	Pump Assembly	1
14	Suction Filter	1
15	Return Line Assembly	1
16	Manifold Assembly	1
17	Valve	1
18	Pressure Transducer	1
19	Control Box Assembly	1

GP2700 / GP6300 / GP6300TX

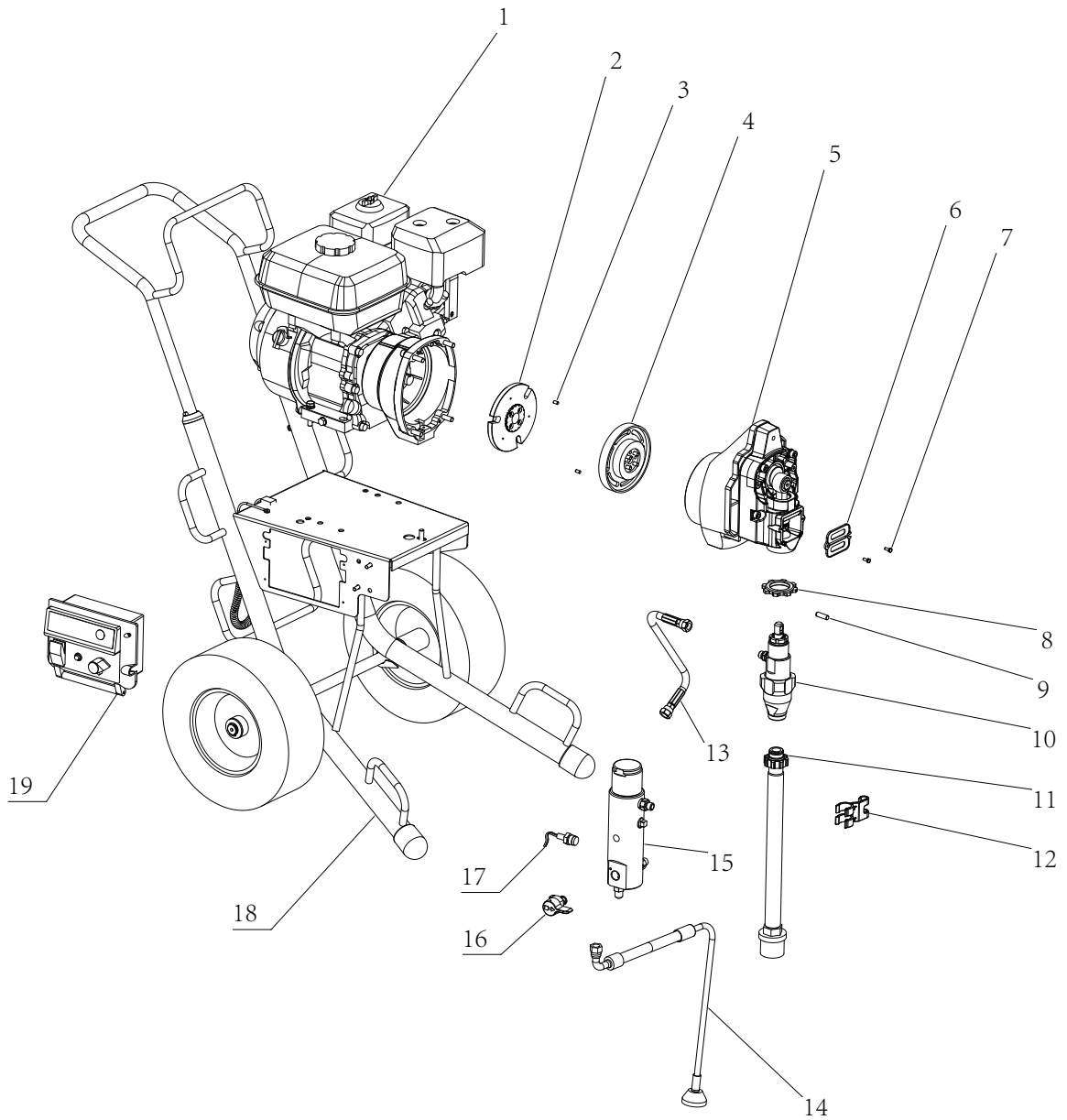

NO	DISCRIPTION	QTY
1	GX160 Engine Assembly	1
2	Clutch Disc	1
3	Pin	2
4	Clutch Disc	1
5	Drive Housing Assembly	1
6	Cover	1
7	Screw	2
8	Nut	1
9	Pin	1
10	Pump Assembly	1
11	Suction Tube	1
12	Hook	1
13	Outlet	1
14	Return Line Assembly	1
15	Manifold Assembly	1
16	Valve	1
17	Pressure Transducer	1
18	Rack	1
19	Control Box Assembly	1

## Pump Assembly For GP8300TX

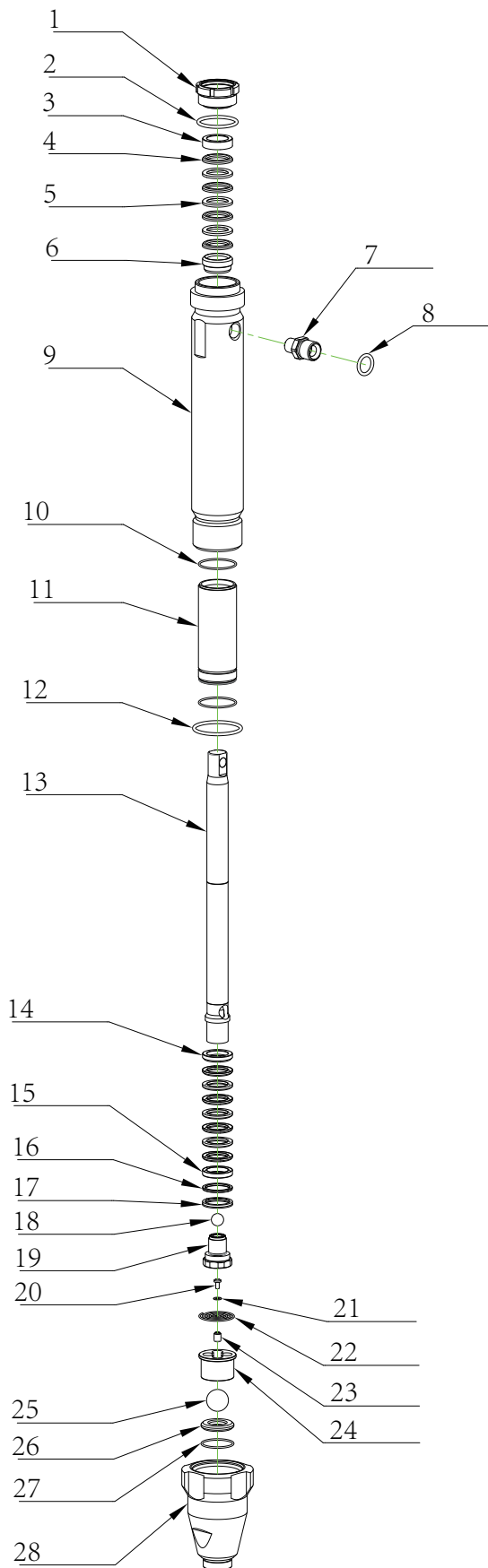

NO	DISCRIPTION	QTY
1	Compression Nut	1
2	O-Ring	1
3	Gland	1
4	V-Packing(Teflon)	8
5	V-Packing(Leather)	6
6	Gland	1
7	Nipple	1
8	O-Ring	1
9	Sleeve	1
10	O-Ring	2
11	Sleeve	1
12	O-Ring	1
13	Displacement Rod	1
14	Gland	1
15	Gland	1
16	Washer	1
17	Seal	1
18	Ball	1
19	Piston	1
20	Screw	1
21	Washer	1
22	Spring	1
23	Nut	1
24	Ball Retainer	1
25	Ball	1
26	Valve	1
27	O-Ring	1
28	Intake-Housing	1

## Manifold Filter Assembly

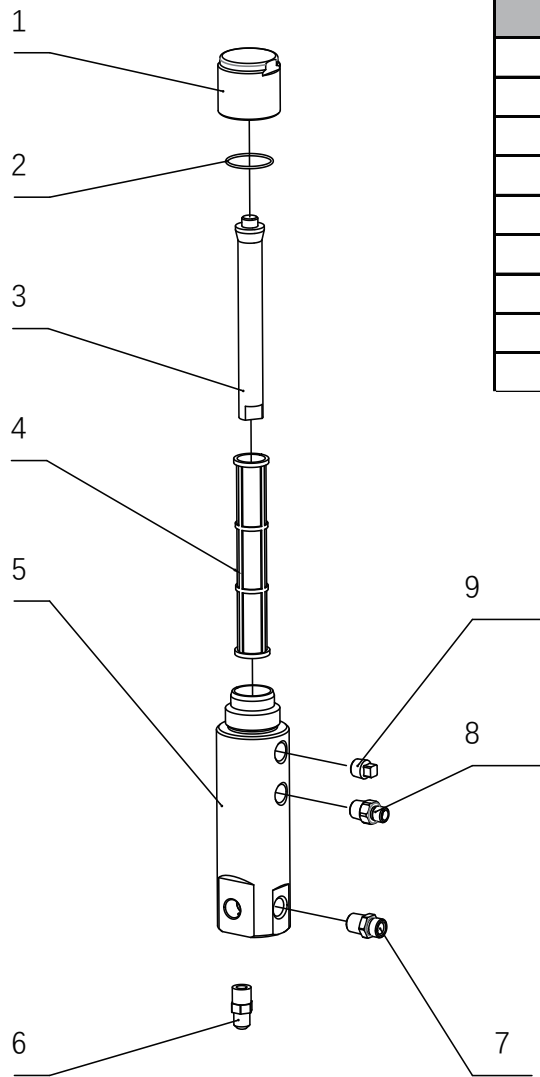

NO.	DISCRIPTION	QTY.
1	Filter cap, manifold	1
2	O-ring	1
3	Inset, filter	1
4	Filter, fluid	1
5	Mainfold, fluid	1
6	Nipple, adapter	1
7	Nipple, adapter	1
8	Nipple, adapter	1
9	Plug	1

## Pump Assembly For GP2700

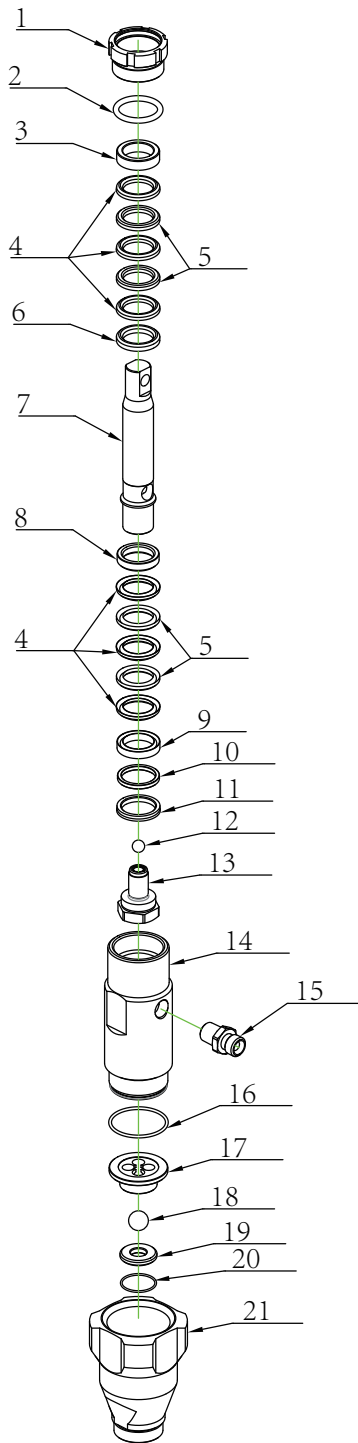

NO	DISCRIPTION	QTY
1	Compression Nut	1
2	O-Ring	1
3	Gland	1
4	V-Packing(Teflon)	6
5	V-Packing(Leather)	4
6	Gland	1
7	Displacement Rod	1
8	Gland	1
9	Gland	1
10	Washer	1
11	Seal	1
12	Ball	1
13	Piston	1
14	Sleeve	1
15	Nipple	1
16	O-Ring	1
17	Ball Retainer	1
18	Ball	1
19	Valve	1
20	O-Ring	1
21	Intake-Housing	1

**Manifold Filter Assembly For GP2700**

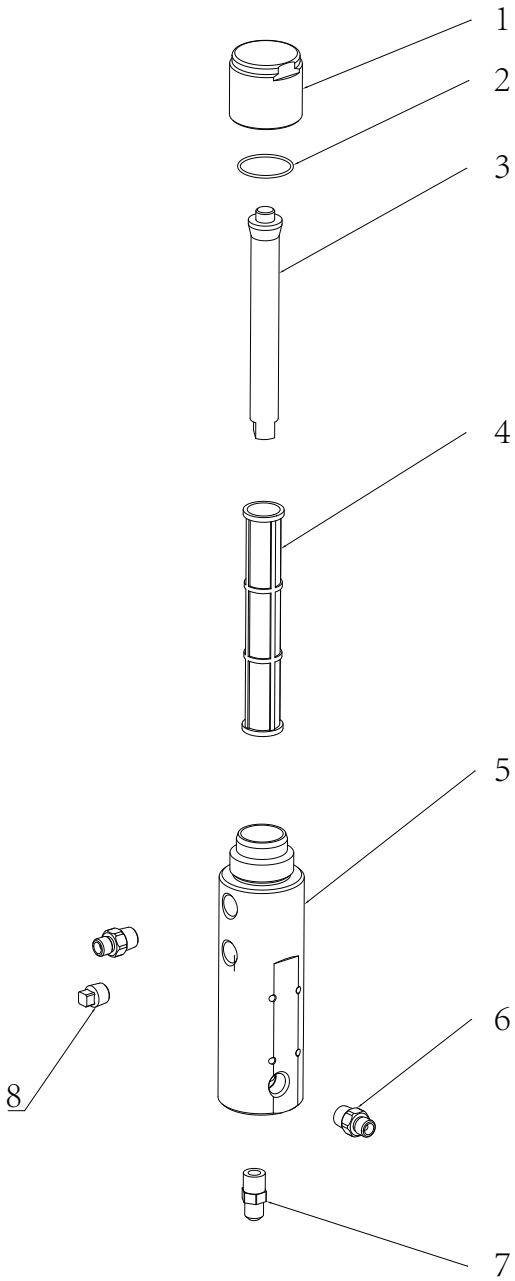

NO.	DISCRIPTION	QTY.
1	Filter cap, manifold	1
2	O-ring	1
3	Inset, filter	1
4	Filter, fluid	1
5	Mainfold, fluid	1
6	Nipple, adapter	1
7	Nipple, adapter	1
8	Plug	1

# Warranty and Limitations

## Warranty General

All HVBAN products have a one year guarantee from the invoice date, unless otherwise stated in writing. The warranty covers all manufacturing faults and material defects. Any spare part replacement or repair operations are covered only if they are carried out by our authorized distributors. This warranty covers when the equipment is installed, operated and maintained in accordance with HVBAN's written recommendations. HVBAN shall not be liable for, any malfunction, damage or wear caused by faulty installation, misapplication, abrasion, corrosion, inadequate or improper maintenance, negligence, accident, tampering, or substitution of Non-HVBAN component parts. This warranty is conditioned upon the CARRIAGE PAID return of the equipment claimed to be defective to an authorized HVBAN distributors for verification of the claim. If the claimed defect is verified, HVBAN will repair or replace free of charge any defective parts. This components will be returned to the original purchase CARRIAGE PAID If inspection of the equipment does not disclose any defect in material or workmanship, repairs will be made at a reasonable charge, which charges may include the costs of parts, labor, and transportation.

The Warranty does not cover

- Damage or breakdown caused by improper use or assembly.
- Damage or breakdown caused by the use of spare parts that are different from the original or recommended ones.
- Damage or breakdown caused by bad preservation.
- **Components subject to wear(described in parts list)**

### Warranty Forfeiture:

- In case of delayed payment or other contractual defaults.
- Whenever changes or repairs are carried out on our equipment without prior authorization.
- When the serial number is damaged or removed.
- When the damage is caused by improper use or functioning, or if the equipment falls, is bumped or by other causes not due to the normal working conditions.
- Whenever the unit disassembled, tampered with or repaired without the authorization of HVBAN.



**FUZHOU HVBAN MECHANICAL EQUIPMENTS CO., LTD**

**No. 2 Plant, Mawei Sci-Tech Innovation Center, No. 56 Kuaizhou Road Liando U Valley,  
Mawei Town, Mawei District, Fuzhou, Fujian, China**

**Zip code:350101**