

HVBAN

Provider of High-Pressure Fluid Equipment Solutions



EP7285 F (380V / 220V)

For spraying or dispensing 1:1 mix ratio materials, including epoxies, polyurethane foam, polyurea coatings, and joint fill materials. For professional use only.



Important Safety Instructions. Read all warnings and instructions in this manual. Save these instructions.

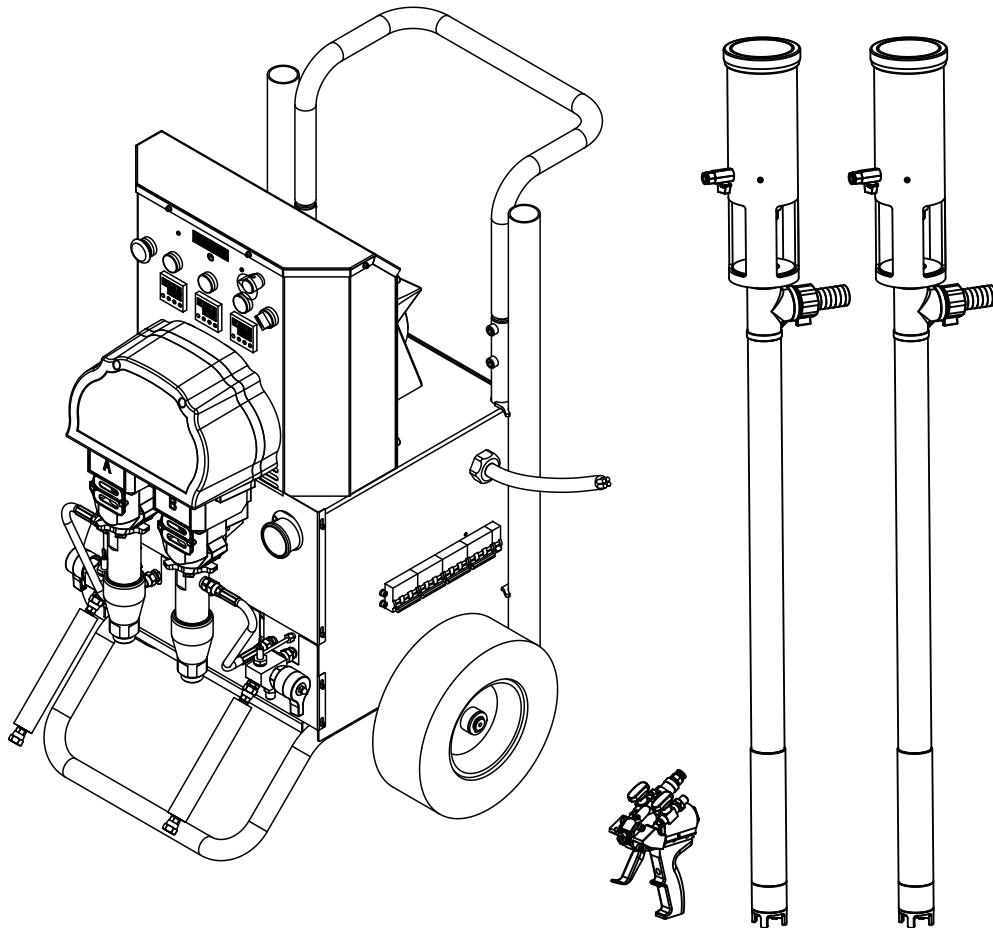





Contents

Warnings.....	3
Important Isocyanate(ISO) Information.....	7
Isocyanate Conditions	7
Material Self-Ignition	8
Keep Components A and B Separate.....	8
Moisture Sensitivity of Isocyanate.....	8
Foam Resins with 245 fa Blowing Agents.....	8
Changing Materials.....	8
Overview.....	9
Component Identification.....	10
Control Panel.....	11
Temperature Controller Display and Setting.....	12
Connect to a Power Source.....	13
Connect the Fluid Hose.....	15
Hose Cleaning.....	16
Heatup Guidelines.....	17
Heating Foam Resins with 245 fa Blowing Agents.....	18
Pressure Relief Procedure.....	19
Pause/Shutdown.....	20
Maintenance.....	21
Flushing.....	22
Purge the Gun Hoses.....	23
Repair the Prime Valve.....	24
Displacement Pump.....	25
Pump Assembly Detailed Diagram.....	26
Electronic Components Diagram.....	27
Replace the Cooling Fan/Transformer.....	29
Replace the Circuit Board/AC Contactor.....	30
Replace the Solid State Relay/Power Switch.....	31
Replace the Motor Fan/Control Panel Assembly.....	32
Control Panel Assembly Diagram.....	33
Replace the Heater.....	34
Heater Assembly Diagram.....	35
Replace the Pump Housing/Connecting Rod/Drive Housing/Motor.....	36
Electronic Component Wiring Diagram.....	37
Dimensions of Main Unit.....	39
Technical Data	40

Warnings

The following warnings are for the setup, use, grounding, maintenance, and repair of this equipment. The exclamation point symbol alerts you to a general warning and the hazard symbols refer to procedure-specific risks. When these symbols appear in the body of this manual or on warning labels, refer back to these Warnings. Product-specific hazard symbols and warnings not covered in this section may appear throughout the body of this manual where applicable.

 WARNING	
 	<p>ELECTRIC SHOCK HAZARD This equipment must be grounded. Improper grounding, setup, or usage of the system can cause electric shock.</p> <ul style="list-style-type: none"> • Turn off and disconnect power cord before servicing equipment. • Connect only to grounded electrical outlets. • Use only 3-wire extension cords. • Ensure ground prongs are intact on power and extension cords. • Do not expose to rain. Store indoors.
	<p>TOXIC FLUID OR FUMES HAZARD Toxic fluids or fumes can cause serious injury or death if splashed in the eyes or on skin, inhaled or swallowed.</p> <ul style="list-style-type: none"> • Read Safety Data Sheets (SDSs) for handling instructions and to know the specific hazards of the fluids you are using, including the effects of long-term exposure. • When spraying, servicing equipment, or when in the work area, always keep work area well-ventilated and always wear appropriate personal protective equipment. See Personal Protective Equipment warnings in this manual. • Store hazardous fluid in approved containers, and dispose of it according to applicable guidelines.
	<p>PERSONAL PROTECTIVE EQUIPMENT Always wear appropriate personal protective equipment and cover all skin when spraying, servicing equipment, or when in the work area. Protective equipment helps prevent serious injury, including long-term exposure; inhalation of toxic fumes, mists or vapors; allergic reaction; burns; eye injury and hearing loss. This protective equipment includes but is not limited to:</p> <ul style="list-style-type: none"> • A properly fitting respirator, which may include a supplied-air respirator, chemically impermeable gloves, protective clothing and foot coverings as recommended by the fluid manufacturer and local regulatory authority. • Protective eyewear and hearing protection.

! WARNING



SKIN INJECTION HAZARD

High-pressure fluid from gun, hose leaks, or ruptured components will pierce skin. This may look like just a cut, but it is a serious injury that can result in amputation. Get immediate surgical treatment.



- Engage trigger lock when not spraying.
- Do not point gun at anyone or at any part of the body.
- Do not put your hand over the spray tip.
- Do not stop or deflect leaks with your hand, body, glove, or rag.
- Follow the Pressure Relief Procedure when you stop spraying and before cleaning, checking, or servicing equipment.
- Tighten all fluid connections before operating the equipment.
- Check hoses and couplings daily. Replace worn or damaged parts immediately.



FIRE AND EXPLOSION HAZARD

Flammable fumes, such as solvent and paint fumes, in work area can ignite or explode. Paint or solvent flowing through the equipment can cause static sparking. To help prevent fire and explosion:









- Use equipment only in well-ventilated area.
- Eliminate all ignition sources; such as pilot lights, cigarettes, portable electric lamps, and plastic drop cloths (potential static sparking).
- Ground all equipment in the work area. See Grounding instructions.
- Never spray or flush solvent at high pressure.
- Keep work area free of debris, including solvent, rags and gasoline.
- Do not plug or unplug power cords, or turn power or light switches on or off when flammable fumes are present.
- Use only grounded hoses.
- Hold gun firmly to side of grounded pail when triggering into pail. Do not use pail liners unless they are anti-static or conductive.
- Stop operation immediately if static sparking occurs or you feel a shock. Do not use equipment until you identify and correct the problem.
- Keep a working fire extinguisher in the work area.





WARNING

  	<p>THERMAL EXPANSION HAZARD Fluids subjected to heat in confined spaces, including hoses, can create a rapid rise in pressure due to the thermal expansion. Over-pressurization can result in equipment rupture and serious injury.</p> <ul style="list-style-type: none"> • Open a valve to relieve the fluid expansion during heating. • Replace hoses proactively at regular intervals based on your operating conditions.
	<p>PRESSURIZED ALUMINUM PARTS HAZARD Use of fluids that are incompatible with aluminum in pressurized equipment can cause serious chemical reaction and equipment rupture. Failure to follow this warning can result in death, serious injury, or property damage.</p> <ul style="list-style-type: none"> • Do not use 1,1,1-trichloroethane, methylene chloride, other halogenated hydrocarbon solvents or fluids containing such solvents. • Do not use chlorine bleach. • Many other fluids may contain chemicals that can react with aluminum. Contact your material supplier for compatibility.
 	<p>EQUIPMENT MISUSE HAZARD Misuse can cause death or serious injury.</p> <ul style="list-style-type: none"> • Do not operate the unit when fatigued or under the influence of drugs or alcohol. • Do not exceed the maximum working pressure or temperature rating of the lowest rated system component. See Technical Specifications in all equipment manuals. • Use fluids and solvents that are compatible with equipment wetted parts. See in all equipment manuals. Read fluid and solvent manufacturer's warnings. For complete information about your material, request Safety Data Sheets (SDSs) from distributor or retailer. • Do not leave the work area while equipment is energized or under pressure. • Turn off all equipment and follow the Pressure Relief Procedure when equipment is not in use. • Check equipment daily. Repair or replace worn or damaged parts immediately with genuine manufacturer's replacement parts only. • Do not alter or modify equipment. Alterations or modifications may void agency approvals and create safety hazards. • Make sure all equipment is rated and approved for the environment in which you are using it. • Use equipment only for its intended purpose. Call your distributor for information. • Route hoses and cables away from traffic areas, sharp edges, moving parts, and hot surfaces. • Do not kink or over bend hoses or use hoses to pull equipment. • Keep children and animals away from work area. • Comply with all applicable safety regulations.

WARNING



MOVING PARTS HAZARD

Moving parts can pinch, cut or amputate fingers and other body parts.

- Keep clear of moving parts.
- Do not operate equipment with protective guards or covers removed.
- Equipment can start without warning. Before checking, moving, or servicing equipment, follow the Pressure Relief Procedure and disconnect all power sources.



BURN HAZARD

Equipment surfaces and fluid that is heated can become very hot during operation. To avoid severe burns:

- Do not touch hot fluid or equipment.

Important Isocyanate (ISO) Information

Isocyanates (ISO) are catalysts used in two component materials.

Isocyanate Conditions

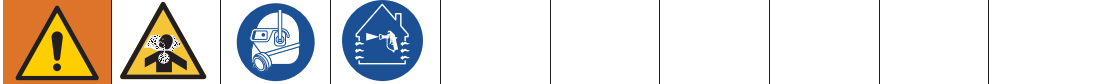



Spraying or dispensing fluids that contain isocyanates creates potentially harmful mists, vapors, and atomized particulates.

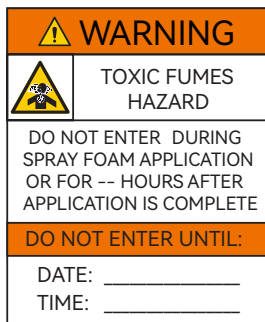

- Read and understand the fluid manufacturer’s warnings and Safety Data Sheets (SDSs) to know specific hazards and precautions related to isocyanates.
- Use of isocyanates involves potentially hazardous procedures. Do not spray with this equipment unless you are trained, qualified, and have read and understood the information in this manual and in the fluid manufacturer’s application instructions and SDSs.
- Use of incorrectly maintained or mis-adjusted equipment may result in improperly cured material, which cause off gassing and offensive odors. Equipment must be carefully maintained and adjusted according to instructions in the manual.
- To prevent inhalation of isocyanate mists, vapors and atomized particulates, everyone in the work area must wear appropriate respiratory protection. Always wear a properly fitting respirator, which may include a supplied-air respirator. Ventilate the work area according to instructions in the fluid manufacturer’s SDSs.
- Avoid all skin contact with isocyanates. Everyone in the work area must wear chemically impermeable gloves, protective clothing and foot coverings as recommended by the fluid manufacturer and local regulatory authority. Follow all fluid manufacturer recommendations, including those regarding handling of contaminated clothing. After spraying, wash hands and face before eating or drinking.
- Hazard from exposure to isocyanates continues after spraying. Anyone without appropriate personal protective equipment must stay out of the work area during application and after application for the time period specified by the fluid manufacturer. Generally this time period is at least 24 hours.
- Warn others who may enter work area of hazard from exposure to isocyanates. Follow the recommendations of the fluid manufacturer and local regulatory authority. Posting a placard such as the following outside the work area is recommended:



Material Self-Ignition

				
Some materials may become self-igniting if applied too thick. Read material manufacturer's warnings and Safety Data Sheets (SDSs).				

Keep Components A and B Separate

				
Cross-contamination can result in cured material in fluid lines which could cause serious injury or damage equipment. To prevent cross-contamination:				
<ul style="list-style-type: none">• Never interchange component A and component B wetted parts.• Never use solvent on one side if it has been contaminated from the other side.				

Moisture Sensitivity of Isocyanates

Exposure to moisture (such as humidity) will cause ISO to partially cure, forming small, hard, abrasive crystal that become suspended in the fluid. Eventually a film will form on the surface and the ISO will begin to gel, increasing in viscosity.

NOTICE				
Partially cured ISO will reduce performance and the life of all wetted parts.				
<ul style="list-style-type: none">• Always use a sealed container with a desiccant dryer in the vent, or a nitrogen atmosphere. Never store ISO in an open container.• Keep the ISO pump wet cup or reservoir (if installed) filled with appropriate lubricant. The lubricant creates a barrier between the ISO and the atmosphere.• Use only moisture-proof hoses compatible with ISO.• Never use reclaimed solvents, which may contain moisture. Always keep solvent containers closed when not in use.• Always lubricate threaded parts with an appropriate lubricant when reassembling.				

NOTE: The amount of film formation and rate of crystallization varies depending on the blend of ISO, the humidity, and the temperature.

Foam Resins with 245 fa Blowing Agents

Some foam blowing agents will froth at temperatures above 90°F(33°C)when not under pressure,especially if agitated. To reduce frothing, minimize preheating in a circulation system.

Changing Materials

NOTICE				
Changing the material types used in your equipment requires special attention to avoid equipment damage and downtime.				
<ul style="list-style-type: none">• When changing materials, flush the equipment multiple times to ensure it is thoroughly clean.• Always clean the fluid inlet strainers after flushing.• Check with your material manufacturer for chemical compatibility.• When changing between epoxies and urethanes or polyureas, disassemble and clean all fluid components and change hoses. Epoxies often have amines on the B (hardener) side. Polyureas often have amines on the B (resin) side.				

Overview

The EP7285 F is a portable, electric-powered, 1:1 mix ratio proportioner, for use with a wide variety of coatings, foams, sealants, and adhesives. Materials must be self-leveling and pourable, and may be applied with impingement mix spray guns, disposable mixer guns, or flush-type mix manifolds.

Severe duty, positive displacement reciprocating piston pumps meter fluid flow to the gun for mixing and applying. When set to recirculation mode, the EP7285 F will circulate fluids back to the supply tanks.

Heated models include separate thermostatically controlled heaters for each fluid, and an insulated hose bundle with circulation return hoses. This allows the hoses and gun to be preheated to the desired temperature before spraying. Digital displays show the temperatures of the two fluids.

An electronic processor controls the motor, monitors fluid pressures, and alerts the operator if errors occur. See STATUS Indicator (ST), page 11, for further information.

The EP7285 F has two recirculation speeds, slow and fast, and an adjustable pressure output.

Slow Recirculation



- Slow circulation results in a higher temperature transfer in the heater, so hoses and gun heat up quicker.
- Good for touchup or low flow spraying, up to moderate temperature.
- Not used to circulate full tanks up to temperature.
- Use with 245 fa blowing agent foams, to minimize heat returned to tank and reduce frothing.

Fast Recirculation



- Use to support higher flow rates or higher temperatures by preheating the tanks.
- Agitates fluid within tanks, to avoid heating only the fluid at the top of the tank.
- Use for flushing.

Pressure Adjust



Automatically maintains selected pressure output for dispensing or spraying.

Component Identification

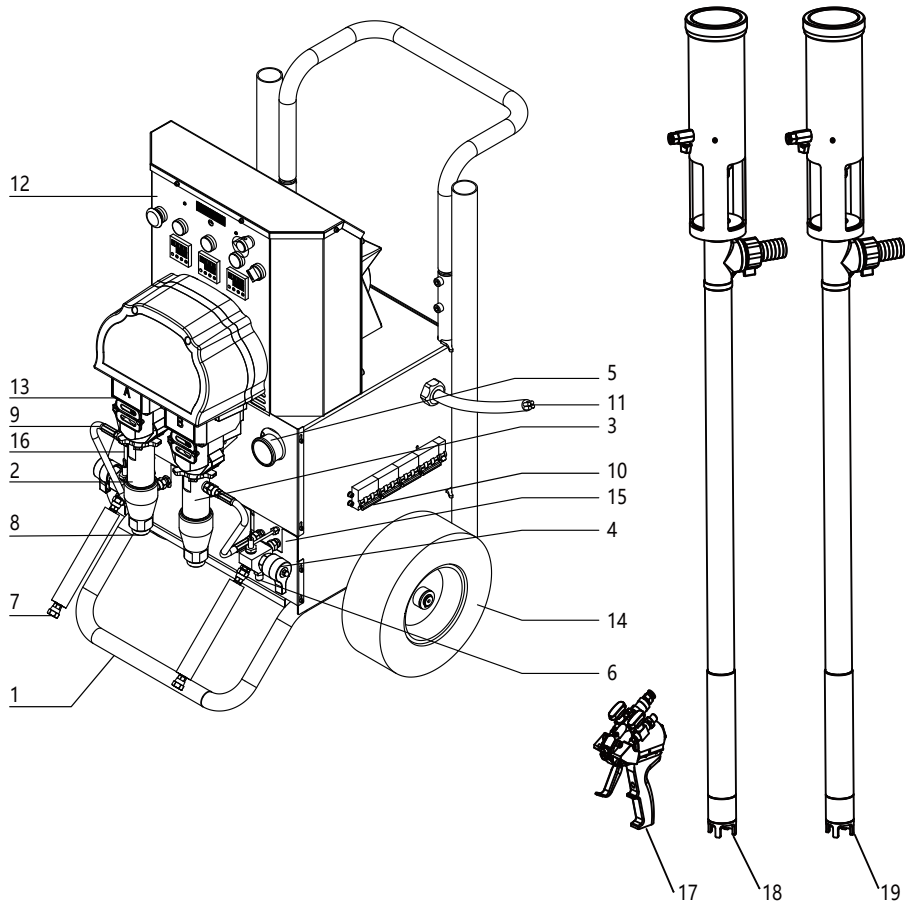

FIG. 1:EP7285 F

KEY

- 1 Rack
- 2 Pump A
- 3 Pump B
- 4 Prime Valve
- 5 Fluid Pressure Gauges
- 6 Return Hose Connections
- 7 Outlet Hose Connections
- 8 Suction Tube Connestions
- 9 Hose
- 10 Power Switch

KEY

- 11 Power Cord
- 12 Control Panel
- 13 Housing
- 14 Tire
- 15 Heater B
- 16 Heater A
- 17 Spray Gun
- 18 Transfer Pump A
- 19 Transfer Pump B

Control panel

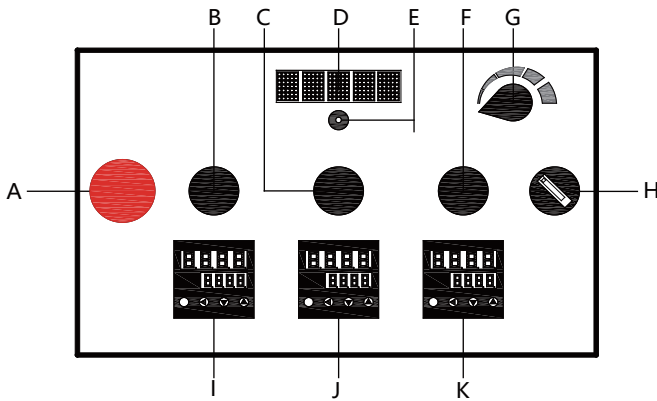

NO	Name
A	Emergency Stop ON/OFF
B	Pump A Heater ON/OFF
C	Pump B Heater ON/OFF
D	Display
E	Display Button
F	Hose Heater ON/OFF
G	Pressure Control
H	Motor ON/OFF
I	Pump A Temperature Controller
J	Pump B Temperature Controller
K	Hose Temperature Controller

FIG. 2 EP7285 F Control Panel

EP7285 F

Motor/Pump Control Function Knob(G)

Use knob (G) to select desired function.

Icon	Setting	Function
	Park	Stops motor and automatically parks pumps
	Slow Recirc	Slow recirculation speed
	Fast Recirc	Fast recirculation speed
	Pressure Adjust	Adjusts fluid pressure to gun in spray mode

Motor Power ON/OFF(H)

Use motor switch (H) to control motor start and stop.

Hose Heater ON/OFF (F)

Use the Hose Heater ON/OFF (F) to control the start and stop of the hose temperature controller (K).

Pump B Heater ON/OFF (C)

Use the Pump B Heater ON/OFF (C) to control the start and stop of the Pump B temperature controller (J).

Pump A Heater ON/OFF (B)

Use the Pump A Heater ON/OFF (B) to control the start and stop of the Pump A temperature controller (I).

Note: For parameter settings and function displays of the temperature controller, please refer to the appendix of the manual.

Display Screen (D)

The display screen (D) normally shows the pump pressure values. By pressing the display button (E) once, you can switch the display to show the motor speed and motor temperature. The display screen also shows error codes when the machine is running. For specific error codes and their causes, see the table below:

Error Codes	Causes of Errors
E=01 Error on Startup	Program error, please restart the machine
E=02 Error on Startup	Communication error, reprogram or replace the circuit board
E=03 Error on Startup	Sensor connection error, reinsert or replace the sensor.
E=05 Error on Startup	Circuit board damage or program corruption
E=05 Error During Operation	Motor coil damage or stator demagnetization
E=07 Error During Operation	Potentiometer damage or sensor failure; Pump pressure too high. Replace the potentiometer or sensor.
E=08 Error on Startup	Low line voltage, please use a voltage stabilizer.
E=09 Error on Startup	Pump blocked by debris, please inspect and repair the pump.
E=10 Error After 5-6 Minutes of Pressure Maintenance	Incorrect program, new program installed on a non-temperature-controlled circuit board
E=11 Error During Operation	High-Pressure Protection: voltage exceeds 310V
Err02 Error on Startup	Program fault or program not successfully reprogrammed

Emergency Stop ON/OFF (A)

Use the Emergency Stop ON/OFF (A) to halt all control components.

Temperature Controller Display and Setting Methods

The Hose Temperature Controller (K), Pump B Temperature Controller (J), and Pump A Temperature Controller (1) are the same model. Therefore, the following instructions apply to all three controllers.

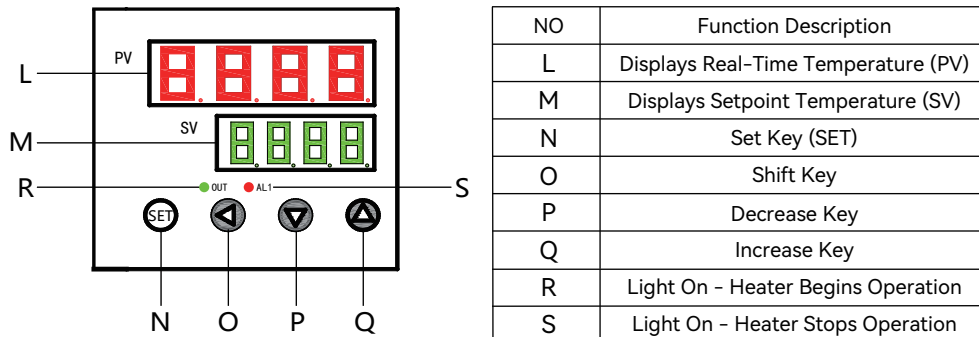

Figure 3: Temperature Controller Values and Key Descriptions

Temperature Controller Setting Methods:

·SV Setting Mode

In the SV/PV normal display mode, press the “SET” key once to make the SV display flash. Use the “<” key to select the digit position for the desired set temperature. Then, use the increase or decrease keys to set the temperature to the desired value. After setting, press the “SET” key again to return to the SV/PV normal display mode.

·Parameter Setting Mode

Secondary Menu: Press and hold the “SET” key for four seconds to enter the secondary menu.

Display Symbols	Name	Description	Setting Range	Default Value
AL1	Alarm Setting Group 1	Set the First Alarm Setpoint	Full Range	10
AL1F	Alarm Method Group 1	0: Upper Limit Deviation 1: Upper Limit Absolute Value 2: Lower Limit Deviation 3: Lower Limit Absolute Value 4: Upper and Lower Deviation Alarm	0-4	0
AL1H	Alarm Hysteresis for Group 1		0.0-9.9	2
HY	Main Control Hysteresis	HY = 0: The instrument uses PID control mode. When HY > 0, the instrument uses a two-position output.	0.0-200	0
T	Proportional Cycle (Seconds)	Set the Control Action Cycle for Heating Side Proportional Cycle	1-99	10
IN	Input Signal Selection	K, E, J,, PT100, Cu50	Five common input signals can be freely selected.	K
SC	Process Value Deviation	The sensor measurement value is added to this value to obtain the PV (Process Value).	-300-300	0.0
SLH	Range	Full Range		Full Range
LCK	Set Data Lock Function	Enable/Disable Data Changes		0
CTRL	PID Mode Control	0: Standard Fixed PID Mode, suitable for applications with low requirements. 1: Slow Integral with No Overshoot Fixed PI Mode. 2: Slow Integral with No Overshoot, Fixed PID Mode with Adjustment Based on Change Trends. 3: Variable-Speed Integral Adjustable P10 Parameter Mode, suitable for rapidly changing systems. 4: Variable-Speed Integral Adjustable PID Parameter Mode, suitable for systems with significant disturbances.		0

1. When HY = 0, the instrument uses PID mode output. When HY ≠ 0, the instrument operates in ON/OFF control mode. In this case, you need to set the control hysteresis value ‘HY’.

Installation

Location

- Place the Reactor EP7285 F on a level surface.
- Do not expose the Reactor EP7285 F to rain.

Grounding

--	--	--	--	--

The equipment must be grounded to reduce the risk of static sparking and electric shock. Electric or static sparking can cause fumes to ignite or explode. Improper grounding can cause electric shock. Grounding provides an escape wire for the electric current.

Reactor EP7285 F: ground through the power cord.

Generator (if used): follow your local code. Start and stop generator with power cord(s) disconnected.

Object being sprayed: follow local code.

Solvent pails used when flushing: follow local code. Use only conductive metal pails, placed on a grounded surface. Do not place the pail on a nonconductive surface, such as paper, plastic, or cardboard, which interrupts grounding continuity.

To maintain grounding continuity when flushing or relieving pressure: hold metal part of the spray gun/dispense valve firmly to the side of a grounded metal pail, then trigger the gun.

Connect to a Power Source

--	--	--	--	--

Improper wiring may cause electric shock or other serious injury if work is not performed properly. All electrical wiring must be done by a qualified electrician and comply with all local codes and regulations.

(380V Type.)

Power Cord Connection Method

Please choose a 380V AC connection, and the connected air switch must have a rated current of more than 40A. The method for connecting the power cord (11) to the air switch is shown in Figure 4-1: the green, red, and yellow wires are connected to the air switch, and the yellow-green wire is connected to the ground.

Power Switch Descriptio

The motor power, pump A heater power, pump B heater power, and hose heater power switches control the 380V AC and fuses. The hose switch controls the transformer to the insulation pipe circuit and fuses. The switch lever up is "ON," and the switch lever down is "OFF."

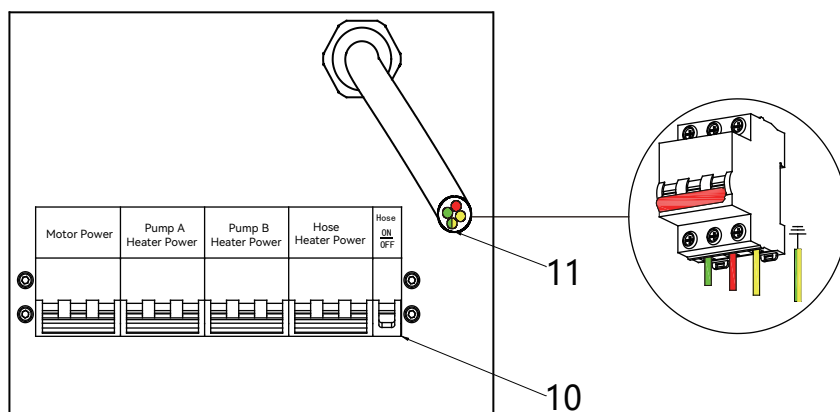

FIG. 4-1 EP7285 F Power Switch and Wiring Method (380V Type.)

Installation

(220V Type.)

Power Cord Connection Method

Please choose a 220V AC connection, and the connected air switch must have a rated current of greater than or equal to 65A. The method for connecting the power cord (11) to the air switch is shown in Figure 4-2: the yellow and brown wires are connected to the air switch, and the green wire is connected to the ground.

Power Switch Descriptio

The motor power, pump A heater power, pump B heater power, and hose heater power switches control the 220V AC and fuses. The hose switch controls the transformer to the insulation pipe circuit and fuses. The switch lever up is "ON," and the switch lever down is "OFF."

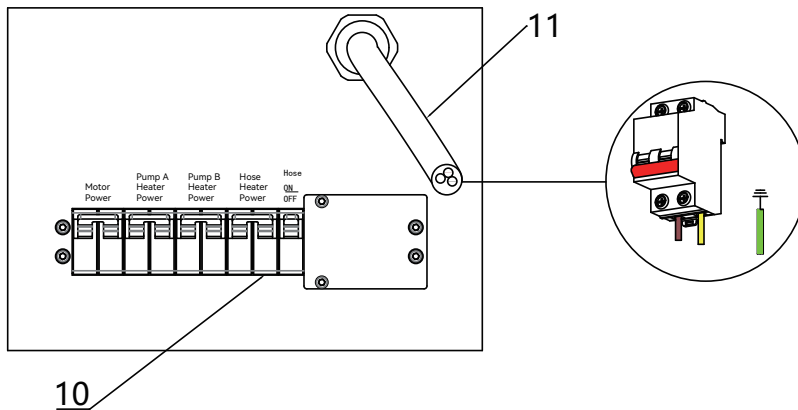

FIG. 4-2 EP7285 F Power Switch and Wiring Method (220V Type.)

Set Up

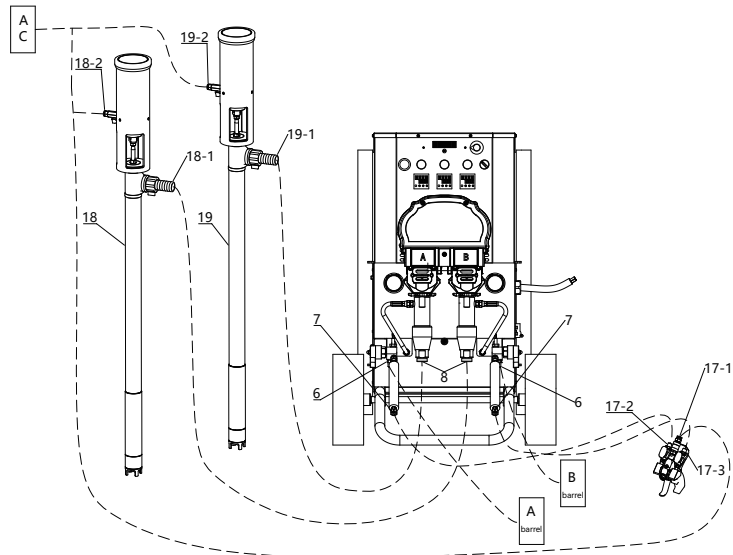

FIG. 5 EP7285 F Hose Connector

Connect the paint delivery pipe

1. Connect the transfer pump hose to the outlet connection (18-1) of Transfer Pump A (18), and the other end to the suction tube connection (8) of Pump A (2).
2. Connect the transfer pump hose to the outlet connection (19-1) of Transfer Pump B (19), and the other end to the suction tube connection (8) of Pump B (3).
3. Connect the spray gun hose to the outlet hose connection (7) on the Pump A (2) side, and the other end to the inlet connection (17-2) on the Spray Gun (17).
4. Connect the spray gun hose to the outlet hose connection (7) on the Pump B (3) side, and the other end to the inlet connection (17-3) on the Spray Gun (17).

Connecting the Return Hose

1. Connect the return hose to the return hose connection (6) on the Pump A (2) side, and the other end to Paint Bucket A.
2. Connect the return hose to the return hose connection (6) on the Pump B (3) side, and the other end to Paint Bucket B.

Connecting the Air Hose

1. Connect the air hose from the included accessories to the air hose quick connector (18-2) on Transfer Pump A (18), and the other end to the air compressor (AC).
2. Connect the air hose from the included accessories to the air hose quick connector (19-2) on Transfer Pump B (19), and the other end to the air compressor (AC).

3. Connect the air hose from the included accessories to the air hose quick connector (17-1) on the Spray Gun (17), and the other end to the air compressor (AC).

Note: The standard output air pressure of the air compressor (AC) must be greater than 0.7 MPa.

Flush Before First Use

The EP7285 F is tested with a plasticizer oil at the factory. Flush out the oil with a compatible solvent before spraying. See Flushing.

Filling the Wet-Cups

Please ensure to use HB pump oil to fill the wet-cups of Pumps A and B as shown in Figure 6, to maintain the lubrication of the sealing rings.

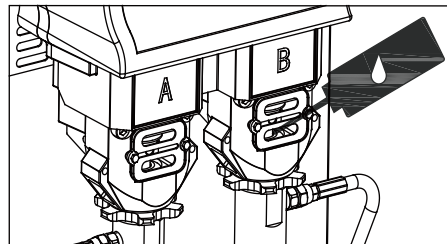
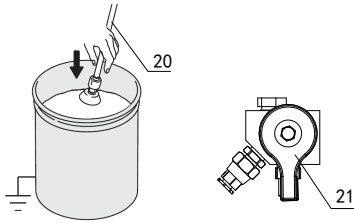

FIG. 6 EP7285 F Pump Oil Filling

Purge Air and Flush the Fluid Lines



1. Prepare two waste containers. Place the return hose (20) from Pump A (2) into one container and the return hose (20) from Pump B (3) into the other container. Then, open the prime valve (21).



2. Set the pressure adjustment knob to Park.

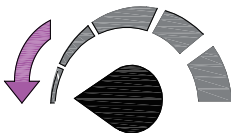

3. Plug in power cord(s). See Figure 4, page 13.

4. Place Transfer Pump A (18) and Transfer Pump B (19) into their paint buckets, preparing them for material transfer.

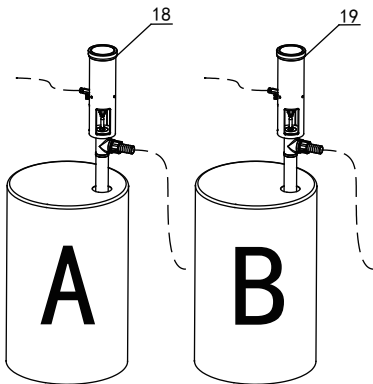

5. Turn on the motor power. Turn on the motor switch.

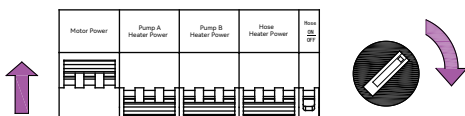

6. Rotate the pressure adjustment knob to "Slow Recirculation" or "Fast Recirculation."

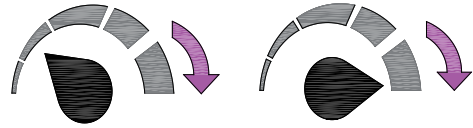

7. Rotate the pressure adjustment knob to the "Park" position once clean fluid flows out from both return hoses (20). Then, return the A and B pump return hoses to their paint buckets. Adjust the pressure knob back to "Slow Recirculation."

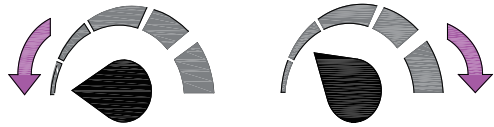

8. Turn on pump A, pump B, and the hose heater power. Activate the hose switch and press switches A, B, C, and F. Set temperature controllers I, J, and K to the target temperature according to the coating requirements (refer to page 12 for the setting method). Allow the coating to circulate through the heaters until the temperature controllers display the real-time temperature as the target temperature.

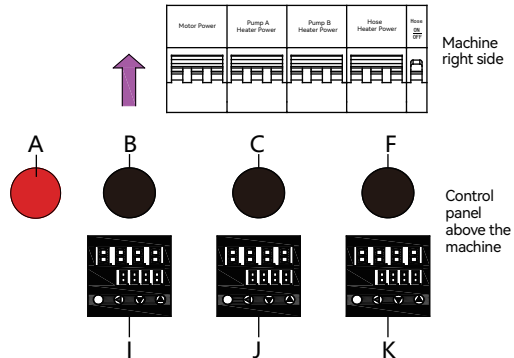

9. Close the prime valve (21) and aim the Spray Gun (17) at the waste container. Activate the Spray Gun. Rotate the pressure adjustment knob to "Slow Recirculation" until clean fluid flows out of the nozzle. Then, rotate the pressure adjustment knob to the "Park" position. The machine is now ready for spraying.

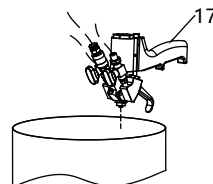

Heatup Time Guidelines for starting a cold machine with 5 gal. (19 l) per side (see Notes below)

Fluid Spray Target Temperature	35 ft (10.7 m) Hose (1 bundle)	70 ft(21 m) Hose (2 bundles)
125° F (52° C)	20 minutes	25 minutes
150° F (65° C)	40 minutes	50 minutes

NOTE: Use fast circulation until temperature is within 20 °F(11 °C) of target, then use slow circulation to reach final temperature. Different fluids will absorb heat at different rates. when refilling a warm machine, heatup times will be less.

Heatup Guidelines

NOTE: The fluids must be circulated from the pumps through the heaters, hoses, and back to the tanks to ensure wamm fluids are supplied to the gun.



Slow Recirculation

- Slow Recirc results in a higher temperature transfer in the heater, so hoses and gun heat up quicker.
- Good for touchup or low flow spraying, up to moderate temperature.
- Not used to circulate full tanks up to temperature.
- Use with 245 fa blowing agent foams, to minimize heat returned to tank and reduce frothing

Fast Recirculation

- Fast Recirc keeps heaters on fulltime to bring fuid tanks up to temperature. The higher your usage rate, the more heat needed in the tanks before spraying.
 - Fornormal usage rates: Use Fast Recirc to get tanks to approximately 50°F (28°C) below desired spray temperature, then use Slow Recirc to raise hose and gun to desired temperature.
 - For higher flow rates or continuous spraying: Use Fast Recirc to bring temperature oftanks to approximately 20°F(11°C) below desired spray temperature, then use Slow Recirc to raise hose and gun to desired temperature.
 - Volume in tanks: Use only what you need. For example, 2.5 gal. (10 l) in each tank will heat up almost twice as fast as 5 gal. (20 l).
- Mixes fluid within tanks, to avoid heating only the fluid at the top of the tank.
- Use for flushing.

Heat Management Tips



- Heaters perform better with lower flow rates or smaller mix modules.
- Triggering the gun for short periods helps maintain efficient heat transfer, keeping material at the desired temperature. Triggering the gun for a long period does not allow enough heating time, and cold material will enter the hose.
- If the temperature displays fall below acceptable limits, set the function knob to Slow Recirc  and circulate again to bring temperatures back up.
- Each 35 ft (10.7 m) hose bundle adds about 5 minutes to heatup time with most materials. Water-based materials take longer to heat up. Maximum recommended hose length is 105 ft (32 m).
- Use Fast Recirc  until the tanks are wam to the touch, then use Slow Recirc  until the displays read desired temperature.
- For a quicker start, do initial heatup circulation with the tanks 1/4 to 1/3 filled, then add more material.

Heating Foam Resins with 245 fa Blowing Agents

New foam blowing agents will froth at temperatures above 90°F (33°C) when not under pressure, especially if agitated.

Never exceed 1/4 of the paint bucket to allow space for foaming when filling the material.

At High Ambient Temperature (above 75°F/24°C)

- Pour resins slowly to avoid frothing.
- Only use Slow Recirc , to avoid heating and agitating the tank. If temperature doesn't keep up, set the function knob to Park  then set to Slow Recirc  again.
- When you stop to refill the tanks, avoid boiling off fluid in the heaters by following these steps.

1. Disconnect the power for Heater B, Heater C, and Heater F.

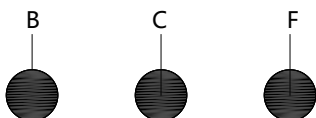

2. Leave the hoses under pressure.
3. Refill the Tanks,
4. Set the Prime valve(21) to Recirc position.

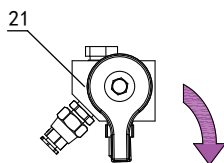



5. Set the function knob to Slow Recirc. 

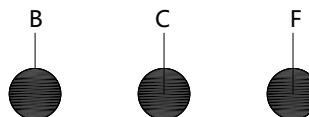

6. Turn on the Power for Heater B, Heater C, and Heater F.



At Cool Ambient Temperature (below 75°F/24°C)

- Use Fast Recirc  to heat the tanks to 75-90°F. (24-32°C), then use Slow Recirc  to raise the hose and gun to desired spray temperature.
- If the top of the resin in tank starts frothing, do not use Fast Recirc  any more.

Spraying/Dispensing



Note: When supplying air to the Spray Gun, close the gun fluid manifold valves 17-4 and 17-5.

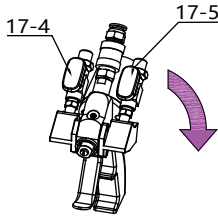

1. Set the function knob to Stop Park.



2. Set the Spray valves to Spray.

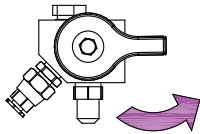

3. Turn the function knob to Pressure Adjust.  Keep turning to the right until the fluid pressure gauges show desired pressure.

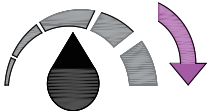

NOTE: Use lower pressures for joint filling applications.

4. Check the fluid pressure gauges to ensure proper pressure balance. If imbalanced, reduce the pressure of the higher component by slightly turning the Spray valve for that component toward Recirc, until the gauges show balanced pressures.

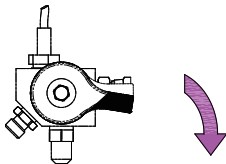

NOTE: Watch the gauges for 10 seconds to be sure the pressure holds on both sides and the pumps are not moving.

5. Open Gun fluid manifold valves 17-4, 17-5.

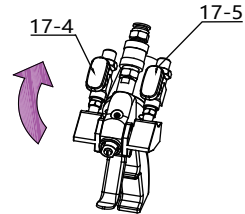

NOTE: Never open the fluid manifold valves or trigger the gun if pressures are imbalanced.

6. Test spray onto cardboard or plastic sheet. Verify that material fully cures in the required length of time, and is the correct color. Adjust the pressure and temperature to get desired results. The equipment is ready to spray.

Pressure Relief Procedure

1. Set the pressure adjustment knob to Park.



2. Slightly turn the prime valves on Pump A and Pump B towards the Recirc. After 5 seconds, turn the prime valves to the Recirc position. Once the gauge drop 0, the pressure relief procedure is complete.

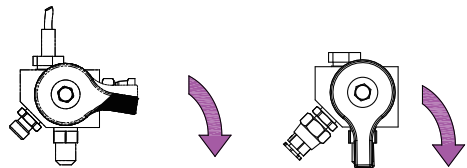

Pause

To bring the hose and gun back to spray temperature after a brief break, use the following procedure.

1. Turn off the switches for the two fluid valves on the spray gun (17-4, 17-5). This action helps keep the internal components of the spray gun clean and prevents cross-contamination.

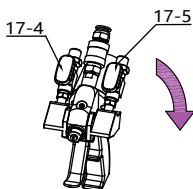

2. Set the function knob to Slow Recirc. 



3. Set Spray valves to Recirc until the temperature readouts come back up.

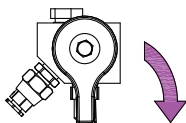

NOTICE

To prevent cross-contamination of fluids and equipment parts, never interchange component A (isocyanate) and component B (resin) parts or containers.

Shutdown



For longer breaks (more than 10 minutes), use the following procedure. If you will be shut down for more than 3 days, first see rilushing. page 21.

1. Follow the Pressure Relief Procedure, page 18.
2. Turn off all heater power supplies, motor power, and hose switches.

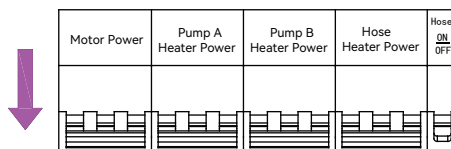

Maintenance

- Check the pump wet-cups fluid level daily, Fill the Wet-Cups, page 14.
- Do not overtighten the packing nut/wet-cup.
- Keep coatings from exposure to moisture in atmosphere to prevent crystallization. For replacement of all wear parts, refer to the corresponding exploded diagram provided later.
- When shutting down, make sure all circuits are disconnected to prevent any hazards.
- Generally, flush if you will shutdown for more than three days. Flush more often if material is moisture sensitive and humidity is high in the storage area, or if material may separate or settle out over time.
- When not in use, close the fluid valves on the spray gun. This helps keep the internal components of the spray gun clean and prevents cross-contamination. Regularly clean the openings of the spray gun mixing chamber and check the check valve filters.

Flushing

<p>To avoid fire and explosion, always ground equipment and waste container. To avoid static sparking and injury from splashing, always flush at the lowest possible pressure. Hot solvent may ignite. To avoid fire and explosion:</p> <ul style="list-style-type: none"> · Flush equipment only in a well-ventilated area. · Ensure main power is off and heaters are cool before flushing. · Do not turn on heater until fluid lines are clear of solvent. 				

- Flush if you will be shut down for more than 3 days. Flush more often if material is moisture sensitive and humidity is high in the storage area, or if material may separate or settle out over time
- Flush out old fluid with new fluid, or flush out old fluid with a compatible solvent before introducing new fluid.
- Use the lowest possible pressure when flushing.
- Always leave some type of fluid in the system. Do not use water.
- For long term storage, flush out the solvent with a storage fluid or, at minimum, clean motor oil.

11. Close fluid valves 17-4 and 17-5. Leave air on.

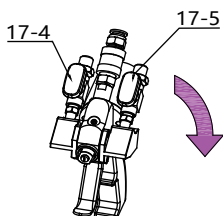

22. Set the function knob to Park.



3. Turn off all heater power supplies, motor power, and hose switches.

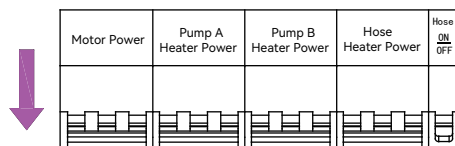

4. Place the return hose (20) into a waste container or paint bucket

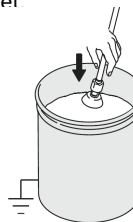

5. Turn the prime valves to Recirc.

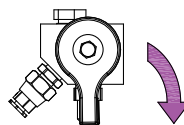

6. Remove transfer pumps A and B from their containers. Place them on a clean surface, adjust the pressure regulation knob to slow recirc,  and start transfer pumps A and B until no more coating flows from the return hose.

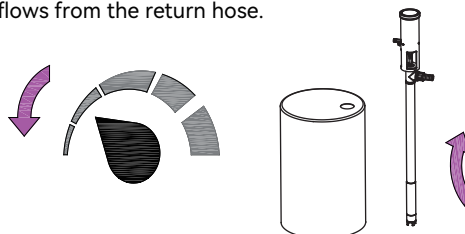

Note: To prevent cross-contamination of coatings, ensure that transfer pump A and transfer pump B are effectively isolated from each other.

7. Set the function knob to Park.



Rinse

7. Prepare two clean containers and fill each with 20-30 liters of cleaning agent. Place Transfer Pumps A and B into the containers. Insert the return hose into the waste container.

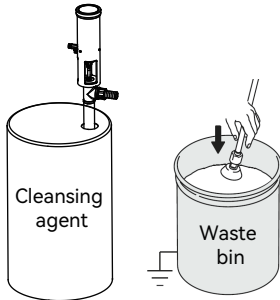

8. Start the transfer pumps and adjust the pressure regulation knob to fast recirc. Observe the return hose until the liquid flowing out becomes clean cleaning material. Then, adjust the pressure regulation knob to the stop position.

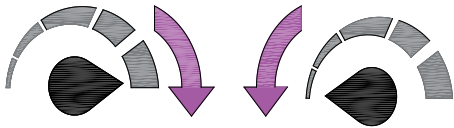

9. Place the return hose into the cleaning material container and adjust the pressure control knob to fast recirc. Allow the cleaning material to circulate through the hose system for 10-20 minutes, then turn the pressure control knob to the stop position.

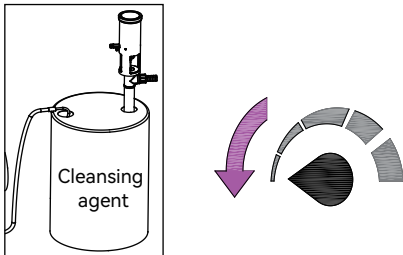

NOTE: Never leave the unit dry unless it has been disassembled and cleaned. If fluid residue dries in the pumps, the ball checks may stick the next time you use the unit causing diminished performance and damage to the system.

Purge the Gun Hoses

1. Turn prime valve to Spray.

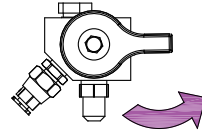

2. Disconnect the hoses from the two connections on the spray gun.

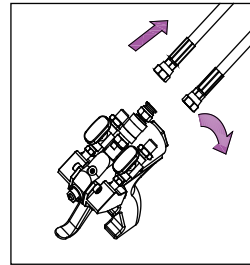

3. Place the hoses into the waste container.

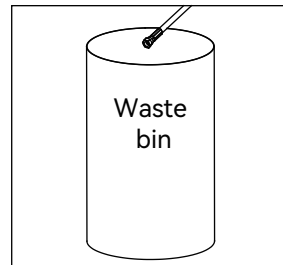

4. Start the transfer pumps and adjust the pressure control knob to slow recirc. Observe the hoses until the liquid flowing out becomes clean cleaning material. Then, turn the pressure control knob to the stop position. This completes the cleaning of the hoses.

Repair

Before Beginning Repair

<p>Repairing this equipment requires access to parts which may cause electric shock or other serious injury if work is not performed properly. Be sure to shut off all power to the equipment before repairing</p>				

1. Flush the system if possible. See Flushing, page 21 if not possible, clean all parts with solvent immediately after removal, to prevent isocyanate from crystallizing due to moisture in the atmosphere.
2. Set the function knob to Park.

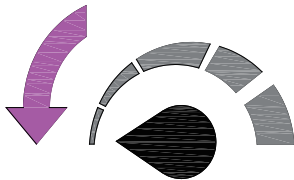

3. Turn off the motor power, heater power, and hose switches. Ensure that the heater has completely cooled down before proceeding to the next step.

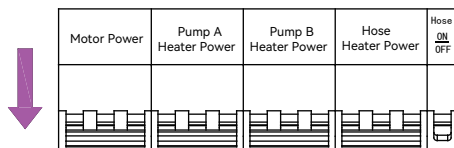

4. Follow the Pressure Relief Procedure, page 18.

Prime Valve



1. Remove the prime valve, as shown in Figure 7.
2. Clean all components and inspect for any damage.
3. Apply PTFE pipe sealant to all tapered pipe threads before reassembling
4. Reassemble according to the instructions in Figure 7, in reverse order.

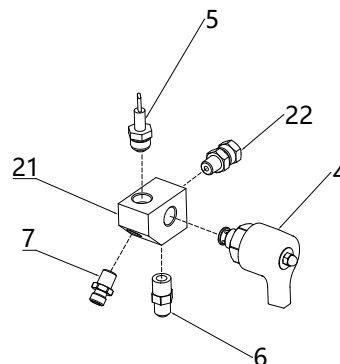

FIG. 7 Prime Valve

KEY

- 4 Prime Valve
- 5 Pressure Sensor
- 6 Return Hose Connections
- 7 Outlet Hose Connections
- 21 Valve Base
- 22 Valve Base Union

Displacement Pump



NOTE: Use a dropcloth or rags to protect the EP 7285 F and surrounding area from spills.

1. Before beginning repair, follow the pressure relief procedure on page 18.
2. Follow the procedures outlined on page 23 before beginning repair.
3. Remove the M8 flat washer (25), spring washer (26), and bolt (27) that secure the machine cover plate (28).

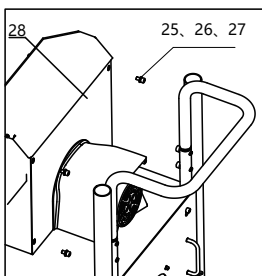

4. Push the machine cover plate (28) along with the machine cover (29) toward the rear of the machine, allowing the motor fan blade (30) to be turned manually.

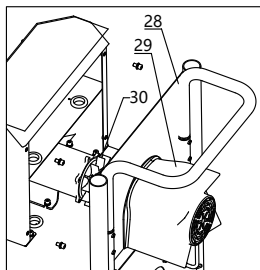

5. Loosen the M6 bolt (31) and slide the protective plate (32) to the left. Rotate the motor cooling fan blade (30) to lower the piston (37) to the bottommost position.

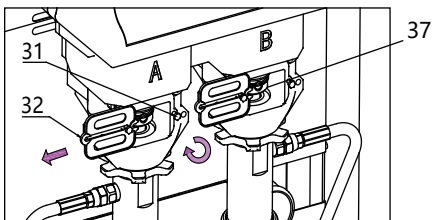

6. Use a flathead screwdriver to pry up the spring retaining ring (33).

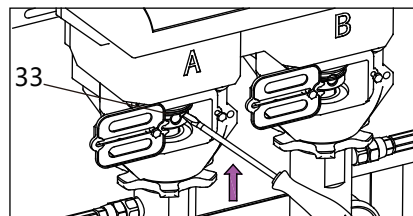

7. Use a flathead screwdriver to gently tap the pin (34) inward.

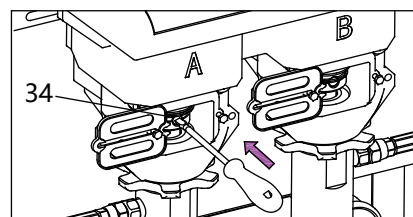

8. Disconnect the hose (9) and remove the suction tube (35). Use a rubber mallet to tap the locking nut (36) clockwise to remove the pump assembly (2, 3).

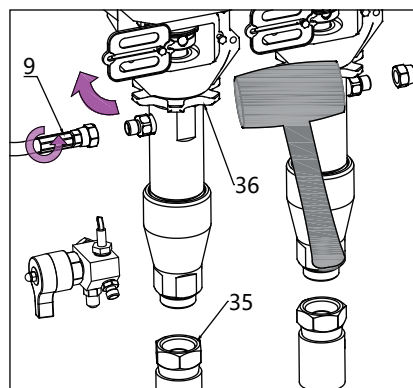

9. To install the pump assembly, follow steps 1-8 in reverse order.

Pump Assembly

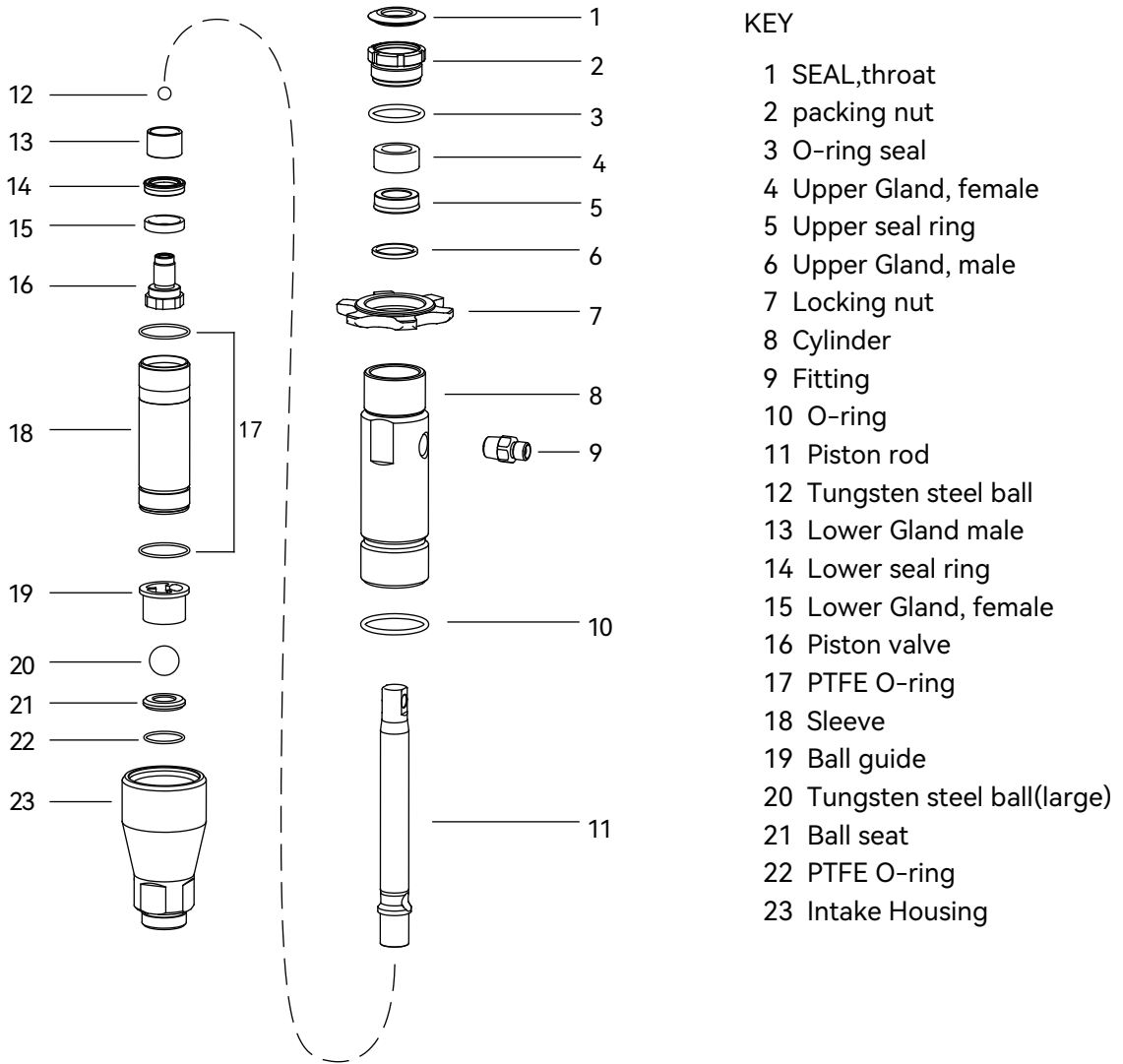

FIG. 8: Pump Assembly Detailed Diagram

Note: The part numbers in Figure 8 are used only for the detailed diagram of the pump assembly on this page and are not related to the overall numbering system.

Diagram for Identifying Electronic Components

(380V Type.)

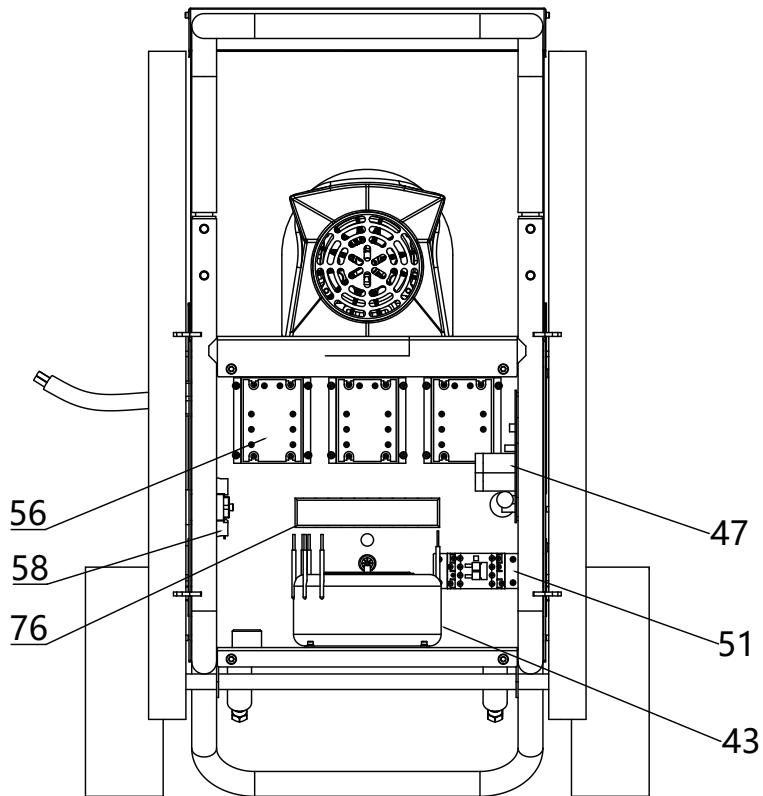

FIG. 9-1: Identification of electronic components (380V Type.)

KEY

- 43 Transformer
- 47 Circuit Board
- 51 AC Contactor
- 56 Solid State Relay
- 58 Power Switch Assembly
- 76 Terminal

Diagram for Identifying Electronic Components

(220V Type.)

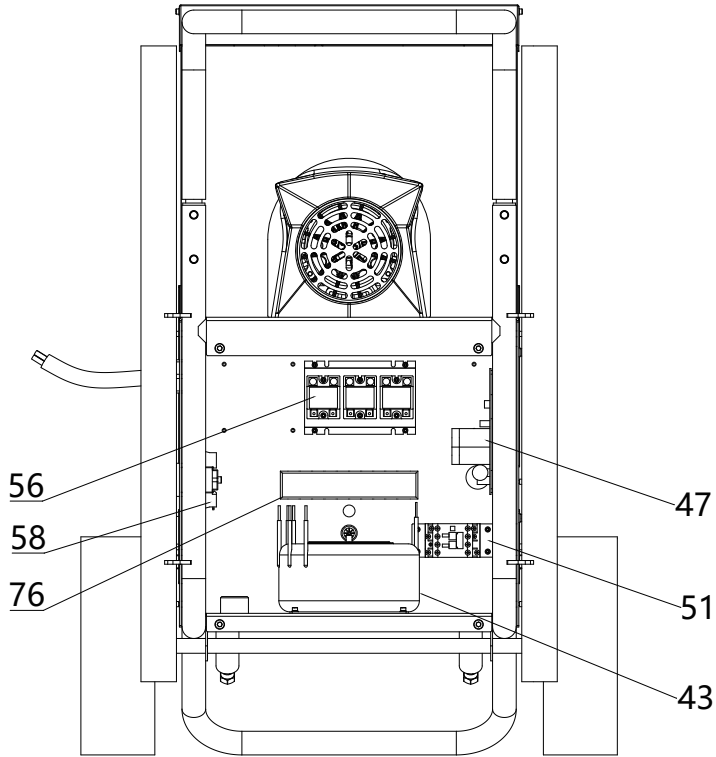

FIG. 9-2: Identification of electronic components (220V Type.)

KEY

- 43 Transformer
- 47 Circuit Board
- 51 AC Contactor
- 56 Solid State Relay
- 58 Power Switch Assembly
- 76 Terminal

Replacing the Cooling Fan

1. Unscrew the four M8 bolts (38).

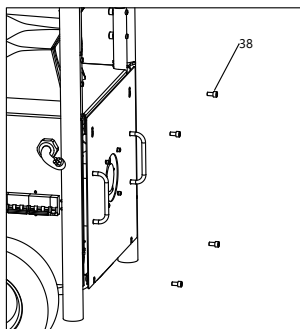

2. Pull out the cooling fan mounting plate (39) and lift the quick-connect terminal (40) to disconnect the cooling fan wiring.)

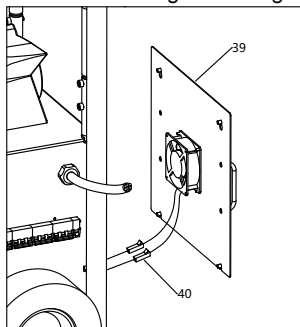

3. Unscrew the four M5 bolts (41) to remove and replace the cooling fan (42).

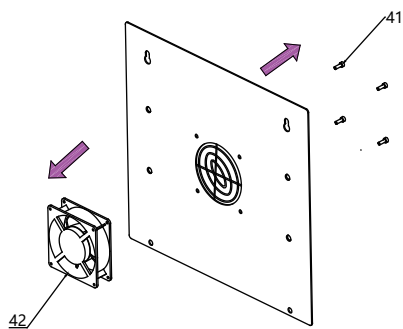

4. To install the new cooling fan (42), follow steps 1-3 in reverse order.

Replacing the Transformer

1. Unscrew the four M4 bolts (44) and remove the M4 flat washers (45) and M4 spring washers (46).

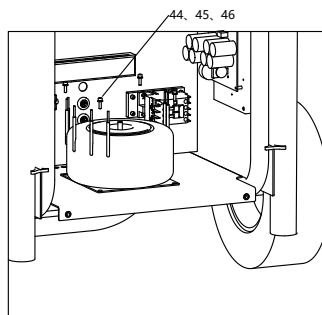

2. Remove the transformer (43) to complete the replacement.

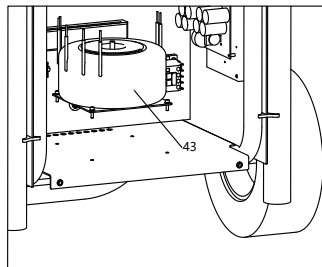

3. To install the new transformer (43), follow steps 1-2 in reverse order.

Replacing the Circuit Board

1. Disconnect all the wires connected to the circuit board (47).

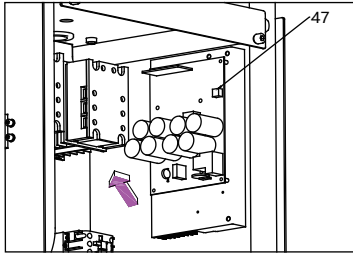

2. Unscrew the three M6 bolts (48) and remove the M6 spring washers (49) and M6 flat washers (50) to detach the circuit board.

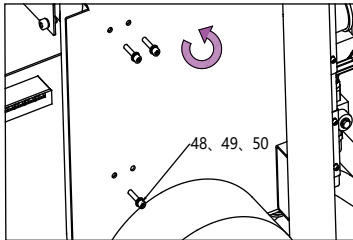

3. To install the new circuit board (47), follow steps 1-2 in reverse order.

Replacing the AC Contactor

1. Use a screwdriver to loosen all bolts securing the wires to the AC contactor (51) and disconnect all the wires.

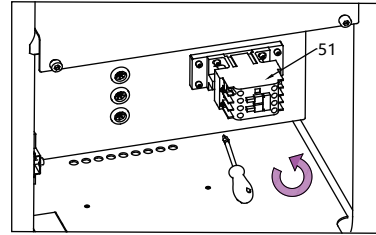

2. Unscrew the M4 bolts (52) securing the AC contactor to the rack, remove the spring washers (53), and detach the base (54).

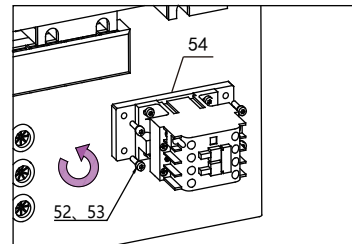

3. Unscrew the M4 bolts (55) securing the AC contactor to the base and remove the AC contactor (51).

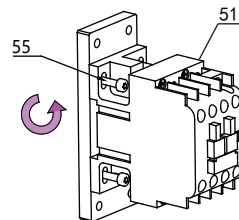

4. To install the new AC contactor, follow steps 1-3 in reverse order.

Replacing the Solid State Relay

1. Use a screwdriver to loosen the bolts securing the wires to the solid state relay (56) and disconnect the wires.

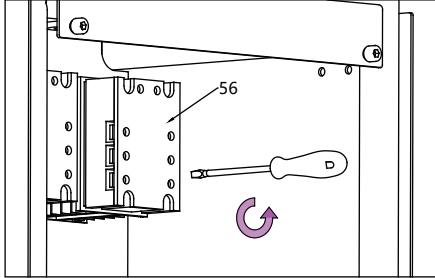

2. Unscrew the M4 bolts (57) securing the solid state relay and remove it.

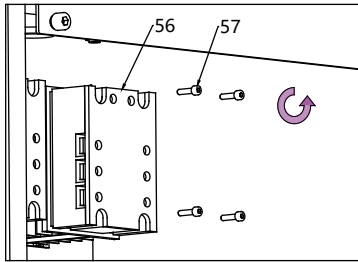

3. To install the new solid state relay, follow steps 1-2 in reverse order.

Replacing the Power Switch

1. Unscrew the M5 bolts (59) and remove the spring washers (60) and flat washers (61).

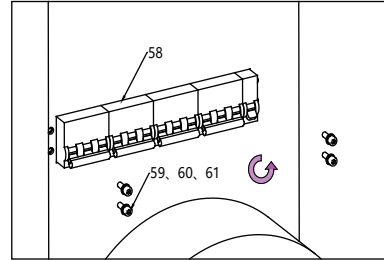

2. Push the power switch assembly (58) inward; use a screwdriver to loosen the bolts securing the connection wires and disconnect all wires.

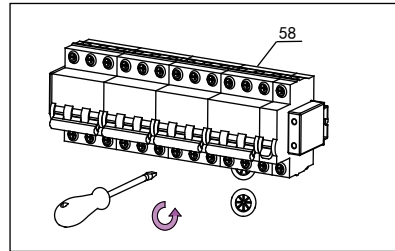

3. Unscrew the M5 bolts (63) and remove the power switch mounting bracket (62).

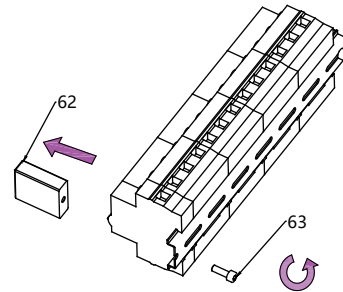

4. Pull the power switch outwards to remove it.

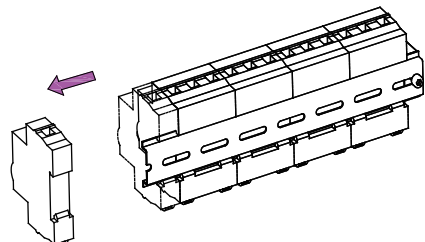

5. To install the new power switch, follow steps 1-4 in reverse order.

Replacing the Motor Fan

1. Remove the machine cover and the cover mounting plate according to step 3 on page 24.
2. Unscrew the self-tapping screws (64).

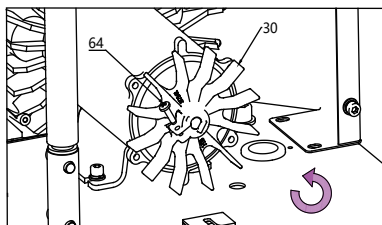

3. Pull the motor fan (30) off the motor (65) to complete the removal.

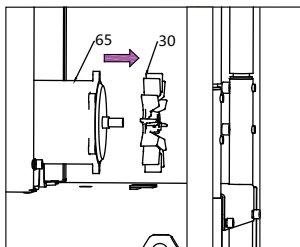

4. To install the new motor fan, follow steps 2-3 in reverse order.

Replacing the Control Panel Assembly

1. Unscrew the M4 bolts (66) and remove the flat washers (67) and the control box cover (65).

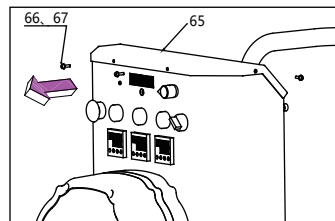

2. Disconnect all wiring from the control panel assembly (68).
3. Unscrew the M8 bolts (69) and remove the spring washers (70) and flat washers (71) to complete the removal of the control panel assembly.

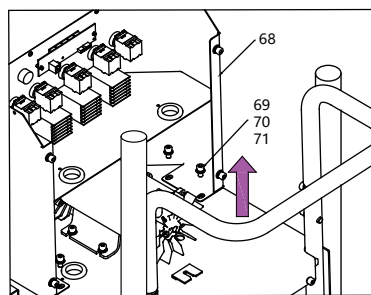

4. To install the new control panel assembly, follow steps 1-3 in reverse order. For details on the components inside the control panel assembly, refer to the "Control Panel Assembly Diagram" on page 30.

Control Panel Assembly Diagram

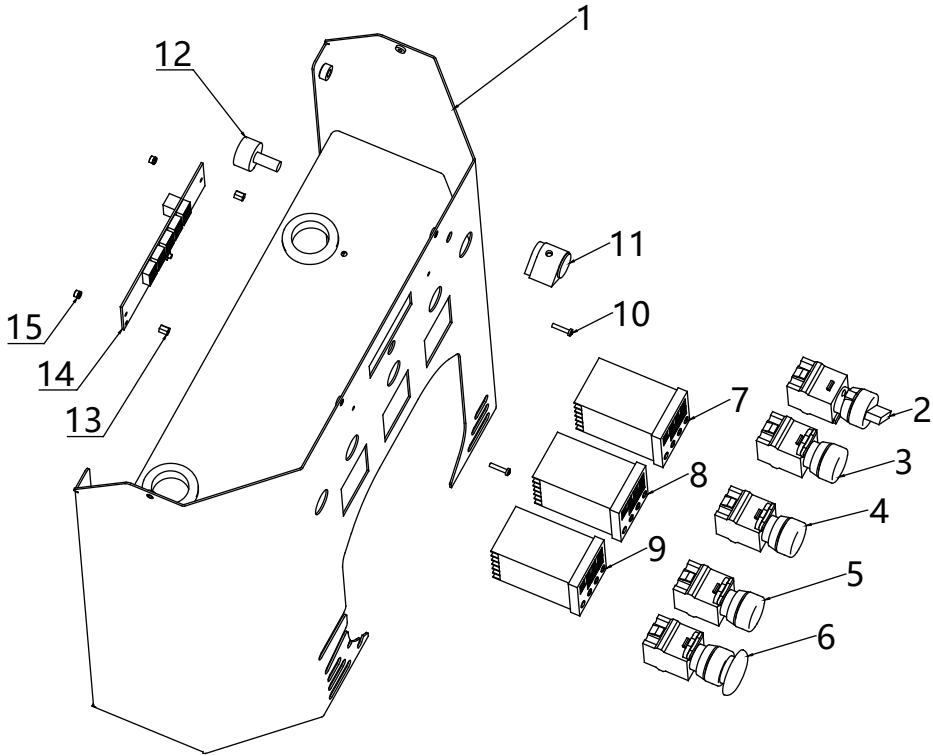

Figure 10: Control Panel Assembly Details

Note: The part numbers in Figure 10 are for reference only within the control panel details on this page and are not related to the overall numbering system.

KEY

- 1 Control Panel Base
- 2 Motor Switch
- 3 Pipeline Heating Switch
- 4 Pump B Heating Switch
- 5 Pump A Heating Switch
- 6 Emergency Stop Switch
- 7 Hose Temperature Controller
- 8 Pump B Temperature Controller

KEY

- 9 Pump A Temperature Controller
- 10 Cross Round Head Bolt
- 11 Pressure Adjustment Knob
- 12 Potentiometer
- 13 Support Column
- 14 Display Screen
- 15 Nut

Replacing the Heater

1. Disassemble the pump assembly following the instructions on page 24.
2. Disassemble the control panel assembly according to the instructions on page 29.
3. Pull out the cable of the temperature sensor (72) and unscrew it from the heater body (79). (When reinstalling, wrap PTFE tape around the threads.) Loosen the pressure gauge seat union (22) and remove the prime valve. Loosen the hose (9) union, and remove the hose.

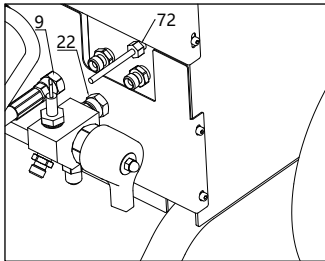

4. Unscrew the M4 bolts (75) securing Heater Cover Plate A (73) and Heater Cover Plate B (74) on both sides, and remove the two cover plates.

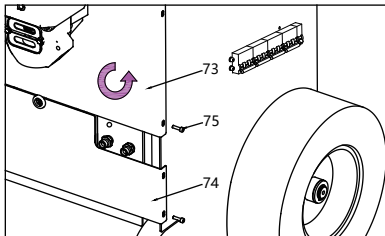

5. Use a screwdriver to loosen the bolts securing the wires on the terminal (76), then disconnect all wires.

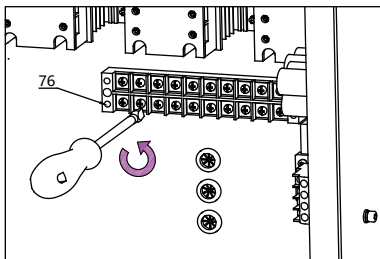

6. Loosen the M14 nuts (78) and unscrew the M14 bolts (77). Then, remove the heater (79).

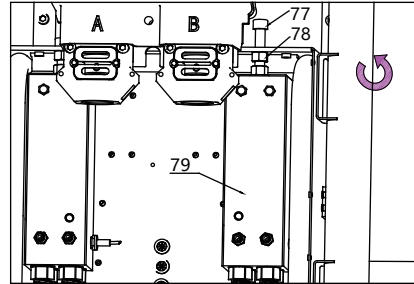

7. To install the heater, follow the steps in reverse order (1-6). For details on the heater components, please refer to the "Heater Assembly Diagram" on page 32.

Heater Assembly Diagram

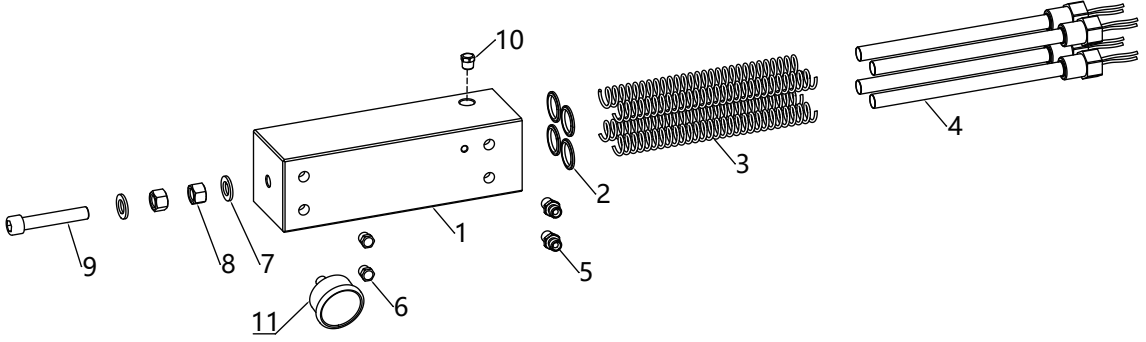

Figure 11: Heater Assembly Detail Diagram

Note: The part numbers listed in Figure 11 are only relevant for the heater assembly detail shown on this page and do not correspond to the overall part numbering system.

KEY

- 1 Heater A/B
- 2 Heating Rod Seal
- 3 Flow Spring
- 4 Heating Rod
- 5 Fluid Connection Bolt
- 6 End Cap

KEY

- 7 M14 Nut
- 8 M14 Washer
- 9 M14 Bolt
- 10 End Cap
- 11 Fluid Pressure Gauge

Replacing the Pump Housing /Connecting Rod

1. Use a screwdriver to remove the M5 Phillips head screws (81) securing the front cover (80), then take off the front cover.

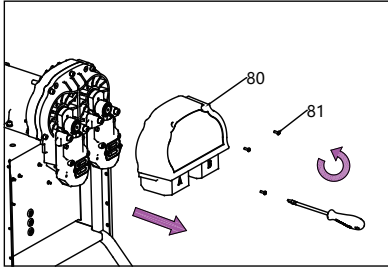

2. Remove the M4 screws (31) and detach the protective plate (32).

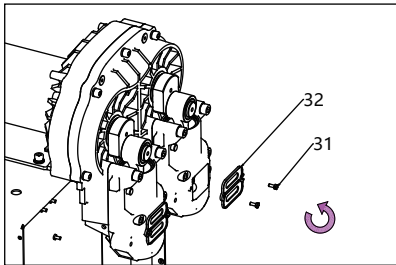

3. Unscrew the M10 bolts (84) and M10 spring washers (85), then pull out the pump housing (83) along with the connecting rod (82). This completes the removal of the pump housing and connecting rod.

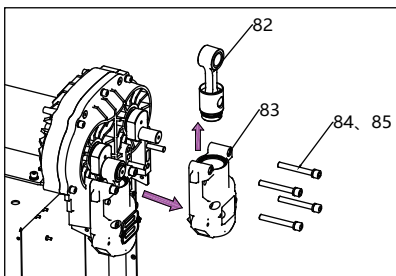

4. To install the pump housing and connecting rod, follow steps 1-3 in reverse order.

Replacing the Drive Housing /Motor

1. Remove the locating pin (86), then unscrew the M8 bolts (87) and M8 spring washers (88).

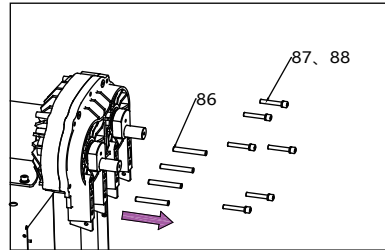

2. Pull out the Drive Housing assembly (89), and remove the copper washer (90), steel washer (91), small copper washers (92, 94), small gear assembly (93), and steel washer (95). This completes the removal of the Drive Housing.

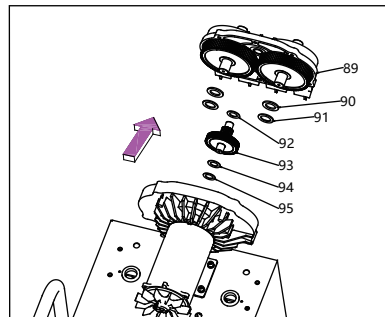

3. Loosen the M8 bolts (96), then remove the M8 spring washers (97) and M8 flat washers (98) to detach the motor (65).

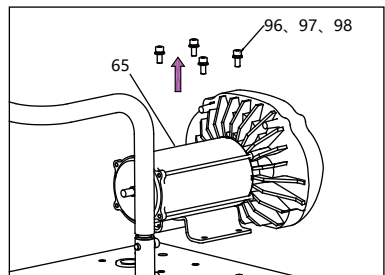

4. To install the Drive Housing, follow steps 1-2 in reverse order. For the motor installation, follow step 3 in reverse order.

Electronic Component Wiring Diagram

(380V Type.)

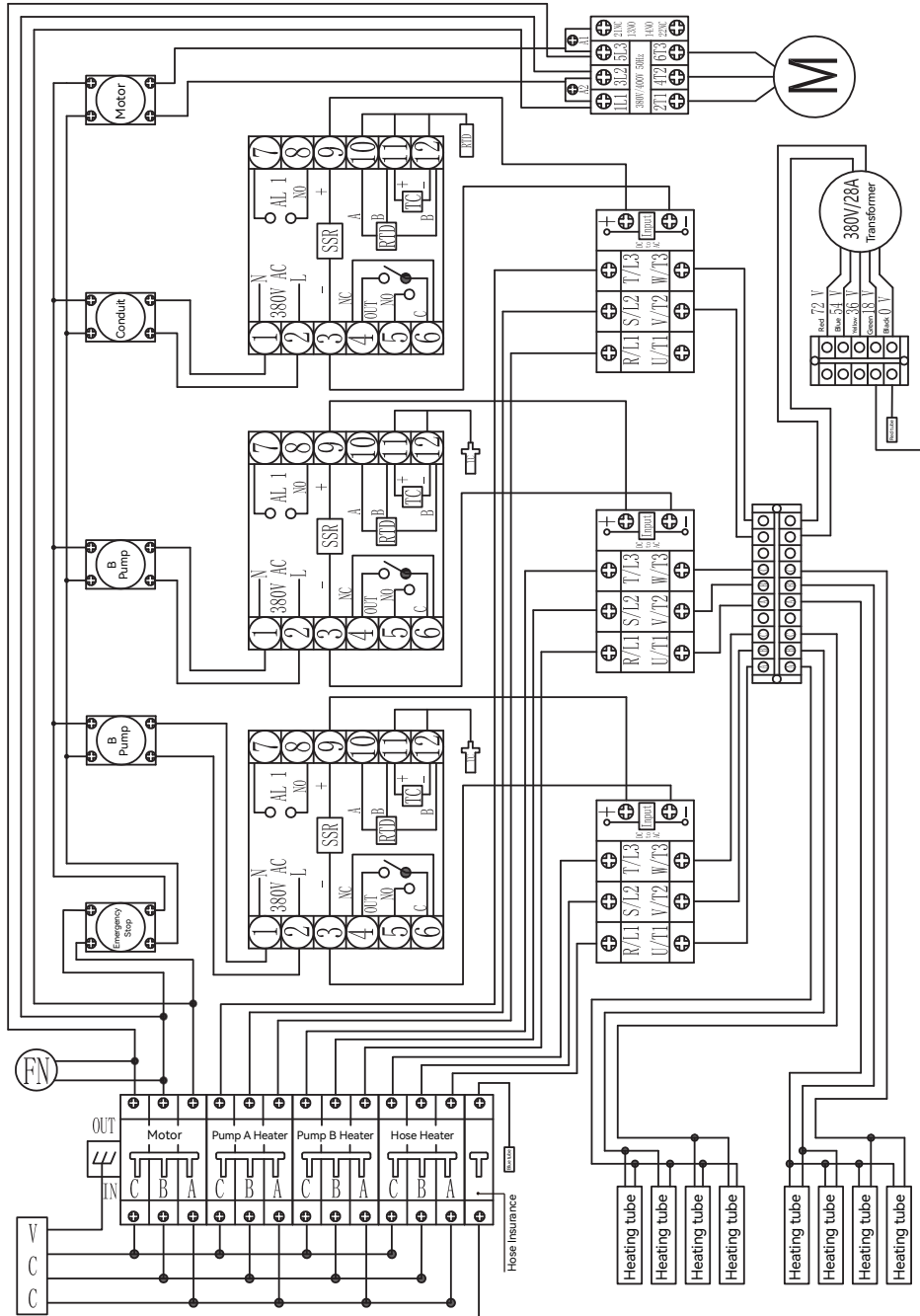

Electronic Component Wiring Diagram

(220V Type.)

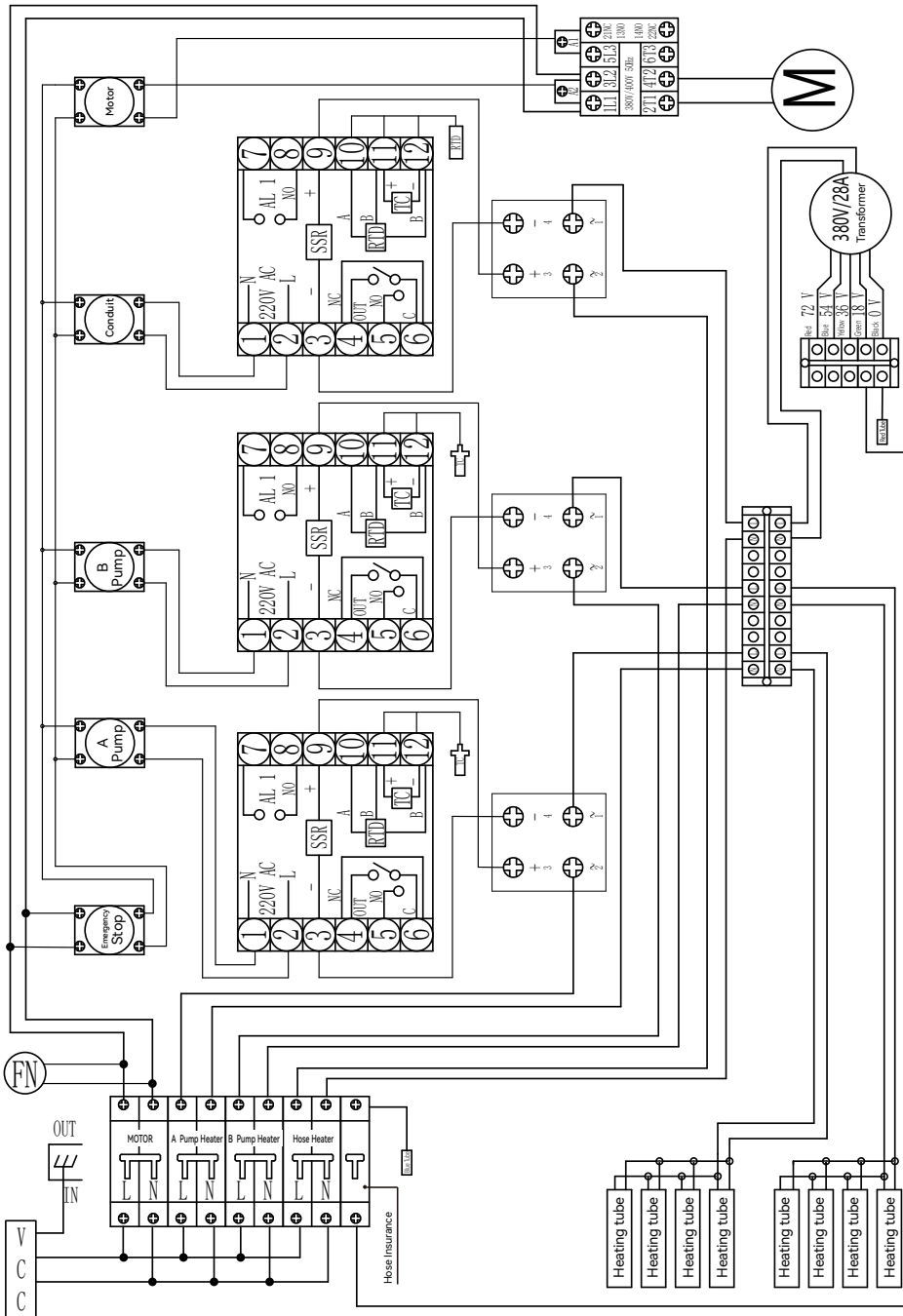

Dimensions of Main Unit

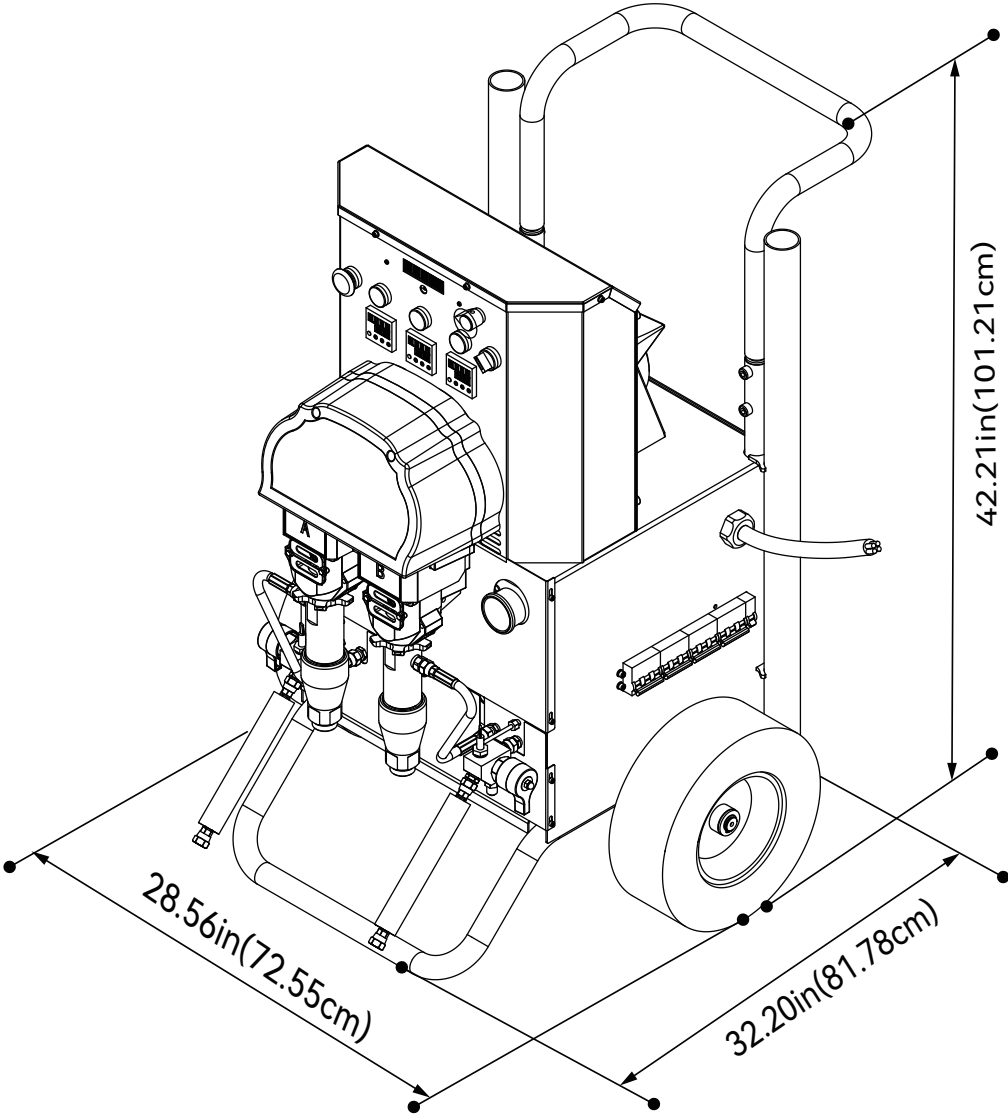

Technical Data

Model	EP 7285 F	
Mixing ratio (vol.)	1:1	
Flow capacity	4-12 L/min	
Max. operating pressure	20 Mpa	
Max. air inlet pressure	5-8 BAR	
Air supply requirement	approx. 600 l/min	
Heated hose max power	2000w	
Max. hose package length	60meter	
Material heaters	8 Kw	
Max. motor power	4 Kw	
Max. temperature	70°C	
Max. power input	14 kw	
Supply voltage	option 1: 220 V /50 HZ	option 2: 380V
Weight	195 Kg	
Package size (L*W*H)	109 x 79 x 118 Cm	
Applicable materials	Polyurethane / Polyurea / Two-Component	
Drive mode	ELECTRIC	
Standard Configuration	15meter hose*1 2.5meter hose*1 spray gun*1	



福州慧邦机械设备有限公司

FUZHOU HVBAN MECHANICAL EQUIPMENTS Co., Ltd.

HVBAN[®]

地址/ADD.: 福州市马尾区马尾镇快洲路56号联东U谷.马尾科创中心2号厂房
No. 2 Plant, Mawei Sci-Tech Innovation Center, No. 56 Kuaizhou Road Liando U Valley,
Mawei Town, Mawei District, Fuzhou, Fujian, China

电话/TEL.: **86-591-87913317** 传真/FAX.: **86-591-88067287**

网址/WEB.: **www.hvbansprayer.com** **www.airless-sprayer.com**

邮箱/E-mail: **hb@airless-sprayer.com** **hb@fzhbgs.com**