

# User Manual

HS 1095/1195/1195HD/1395HD/1595HD/6495

## Electric Airless Sprayer



**Important Safety Instructions.** Read all warnings and instructions in this manual. Save these instructions.

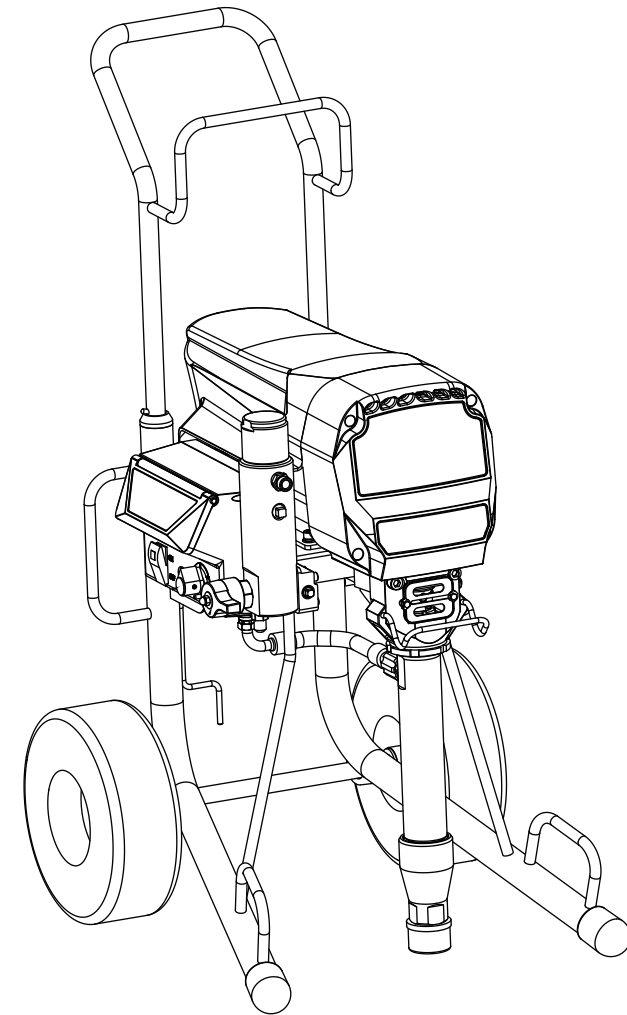

**福州慧邦机械设备有限公司**

**HVBAN<sup>®</sup> FUZHOU HVBAN MECHANICAL EQUIPMENTS Co., Ltd.**







地址/ADD.: 福州市马尾区马尾镇快洲路56号联东U谷·马尾科创中心2号厂房  
No. 2 Plant, Mawei Sci-Tech Innovation Center, No. 56 Kuaizhou Road Liando U Valley,  
Mawei Town, Mawei District, Fuzhou, Fujian, China















电话/TEL.: 86-591-87913317 传真/FAX.: 86-591-88067287

网址/WEB.: [www.hvbansprayer.com](http://www.hvbansprayer.com) [www.airless-sprayer.com](http://www.airless-sprayer.com)

邮箱/E-mail: [hb@airless-sprayer.com](mailto:hb@airless-sprayer.com) [hb@fzhbgs.com](mailto:hb@fzhbgs.com)



 <b>WARNING</b>	
	<p>These warnings cover the setup, use, grounding, maintenance, and repair of this equipment. The exclamation mark indicates general warnings, while specific symbols denote particular hazards. Refer to these warnings whenever symbols appear in the manual or on labels. Additional product-specific warnings may be found elsewhere in this manual.</p>
	<p><b>GROUNDING</b></p> <p>This product must be grounded to safely discharge current in case of a short circuit, reducing the risk of electric shock. Use the provided power cord with a grounded plug, and connect it to a properly installed, grounded outlet as per local regulations.</p> <ul style="list-style-type: none"> <li>• Improper installation of the grounding plug may result in the risk of electric shock.</li> <li>• When repairing or replacing the cord or plug, do not connect the grounding wire to any flat prong.</li> <li>• The grounding wire is indicated by the outer surface of its insulation being green (with or without yellow stripes).</li> <li>• If you do not fully understand the grounding instructions, or if you are unsure whether the product is properly grounded, consult a qualified electrician or repair personnel.</li> <li>• Do not modify the provided plug. If it does not fit into your power outlet, have a qualified electrician install a suitable outlet.</li> <li>• This product is suitable for use on circuits with a nominal voltage of 220 volts.</li> <li>• This product can only be connected to a power outlet with a matching plug configuration.</li> <li>• This product should not be used with an adapter.</li> </ul> <p><b>Extension Cords:</b></p> <ul style="list-style-type: none"> <li>• Only use a 3-core extension cord, with one end having a grounding plug and the other end having a grounded outlet compatible with the plug supplied with this product.</li> <li>• Ensure that the extension cord you use is not damaged. If an extension cord is necessary, use one with a minimum wire size of 2.5 mm<sup>2</sup> to carry the current required by this device.</li> <li>• Using an extension cord with an inadequate wire size can lead to voltage drops, power loss, and overheating.</li> </ul>
    	<p><b>Fire and Explosion Hazards</b></p> <p>The presence of flammable mists from solvents, coatings, or fumes in the work area poses a fire or explosion risk. To prevent fires and explosions:</p> <ul style="list-style-type: none"> <li>• Do not spray flammable or combustible coatings near open flames or sources of ignition, such as cigarettes, motors, and electrical equipment.</li> <li>• Coatings or solvents flowing through this spray machine can generate static electricity. In the presence of solvent or coating mists, static electricity poses a fire or explosion hazard. All parts of the spraying system, including pumps, hose assemblies, spray guns, and surrounding objects, must be properly grounded to prevent static discharge and sparks. Use grounded high-pressure airless paint spray hoses.</li> <li>• Ensure all containers and collection systems are grounded to prevent static discharge. Do not use bucket liners unless they are anti-static or conductive.</li> <li>• Connected outlets or extension cords must be grounded. Do not use 3-prong to 2-prong adapters.</li> <li>• Do not use coatings or solvents containing halogenated hydrocarbons.</li> <li>• Maintain good ventilation in the spraying area. Ensure plenty of fresh air circulation and keep pump components in well-ventilated locations. Do not spray on pump components.</li> <li>• No smoking in the spraying area.</li> <li>• Avoid operating light switches, engines, or other products that may produce electrical sparks in the spraying area.</li> <li>• Keep the area clean and free of paint or solvent containers, debris, and other combustible materials.</li> <li>• Be aware of the components of the paints and solvents being used. Read all Material Safety Data Sheets (MSDS) and container labels accompanying the paints and solvents, and follow the safety instructions provided by the manufacturers.</li> <li>• Ensure that effective firefighting equipment is available.</li> <li>• The spray machine may generate electrical sparks. Maintain a distance of at least 20 feet (6 meters) from explosive vapors when using flammable fluids or cleaning with flammable fluids near the spray machine.</li> </ul>

 <b>WARNING</b>	
  	<p><b>Skin Injection Hazards</b></p> <p>High-pressure spraying can inject toxic substances into the body, leading to serious injuries. If injected into the skin, seek surgical treatment immediately.</p> <ul style="list-style-type: none"> <li>• Never aim the spray gun at anyone or any animal, and do not spray toward them.</li> <li>• Keep hands and other body parts away from the spray. For example, do not attempt to block the paint flow with any part of your body.</li> <li>• Always use a nozzle guard. Do not spray without the nozzle guard installed.</li> <li>• Be cautious when cleaning or replacing the nozzle. If it clogs during spraying, release the pressure and turn off the machine before removing the nozzle for cleaning.</li> <li>• Do not leave the spray machine powered on or pressurized when unattended. When not in use, follow the pressure release steps and turn off the machine.</li> <li>• Inspect hoses and parts for signs of damage. Replace any damaged hoses or parts.</li> <li>• This system can generate working pressures of 3300 psi (227 bar, 22.7 MPa). Use replacement parts or accessories rated for at least 3300 psi (227 bar, 22.7 MPa).</li> <li>• Always lock the trigger lock when not spraying. Ensure the trigger lock is functioning correctly.</li> <li>• Confirm that all connections are secure before operating the equipment.</li> <li>• Know how to quickly shut down and relieve pressure. Be thoroughly familiar with the control devices.</li> </ul>
 	<p><b>Hazards of Equipment Misuse</b></p> <p>Misusing equipment can lead to serious injuries or fatalities.</p> <ul style="list-style-type: none"> <li>• Always wear appropriate gloves, goggles, and a respirator or face shield while spraying.</li> <li>• Do not operate or spray near children. Always keep children away from the spray machine.</li> <li>• Avoid leaning excessively or standing on unstable platforms. Always maintain a stable footing and balance.</li> <li>• Stay alert and focus on what you are doing.</li> <li>• Do not leave the spray machine powered on or pressurized when unattended. When not in use, follow the pressure release steps and turn off the machine.</li> <li>• Do not use this equipment when fatigued, or after using drugs or alcohol.</li> <li>• Avoid twisting or over-bending hoses.</li> <li>• Do not expose hoses to temperatures or pressures beyond specified limits.</li> <li>• Do not use hoses to pull or lift equipment.</li> <li>• Do not use hoses shorter than 25 feet for spraying.</li> <li>• Do not modify or alter the equipment. Modifications can void certifications and create safety hazards.</li> <li>• Ensure that all equipment is rated and certified for your intended use environment.</li> </ul>
  	<p><b>Electric Shock Hazards</b></p> <p>This equipment must be properly grounded. Improper grounding, incorrect setup, or misuse can lead to electric shock.</p> <ul style="list-style-type: none"> <li>• Before servicing the equipment, turn off the power and disconnect the power supply.</li> <li>• Only connect to a properly grounded power outlet.</li> <li>• Use only three-prong extension cords.</li> <li>• Ensure that the grounding prongs on the power supply and extension cords are intact.</li> <li>• Do not expose the equipment to rain. Store it indoors.</li> <li>• Wait at least 5 minutes after disconnecting the power supply before servicing large capacitor devices.</li> </ul>
 	<p><b>Hazards of High-Pressure Aluminum Components</b></p> <p>Using fluids incompatible with aluminum in pressurized equipment can cause severe chemical reactions and equipment failure, potentially leading to death, serious injury, or property damage.</p> <ul style="list-style-type: none"> <li>• Do not use 1,1,1-trichloroethane, dichloromethane, other halogenated solvents, or fluids containing these solvents.</li> <li>• Many other fluids may contain substances that react with aluminum. Contact your material supplier for compatibility information.</li> </ul>
  	<p><b>Hazards of Moving Parts</b></p> <p>Moving parts can pinch or sever fingers and other body parts.</p> <ul style="list-style-type: none"> <li>• Avoid contact with moving parts.</li> <li>• Do not operate the equipment when guards are removed or covers are open.</li> <li>• Pressurized equipment may start without warning. Before inspecting, moving, or servicing the equipment, follow the depressurization steps and disconnect all power sources.</li> </ul>

# Component Identification

HS 1095/1195/1195HD/1395HD/1595HD

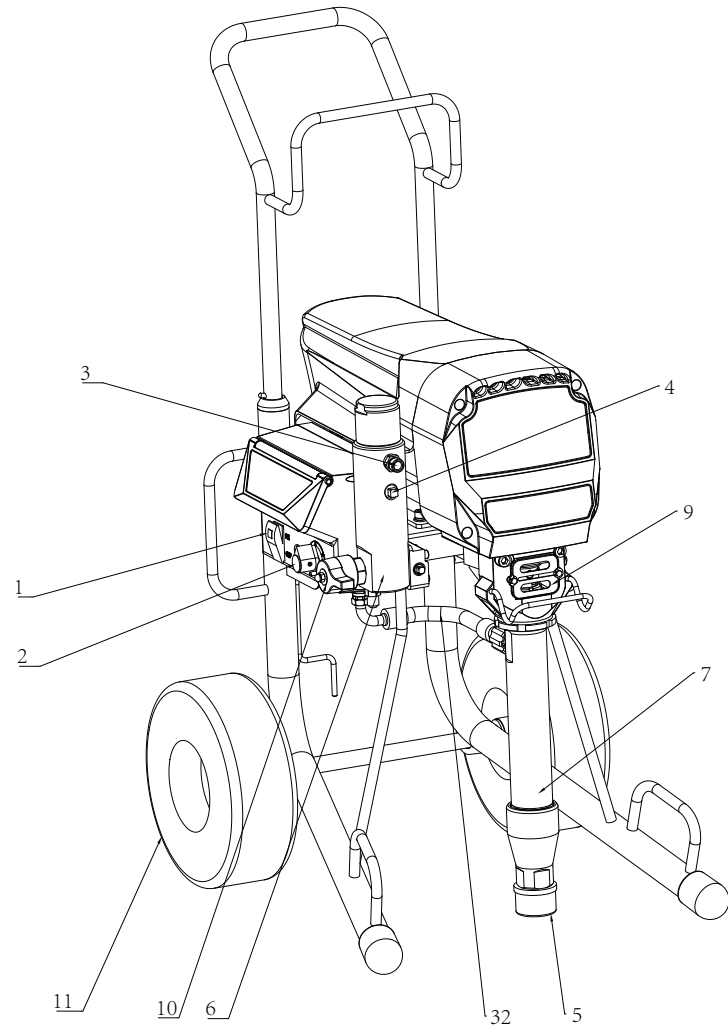

NO	Name
1	Power Switch
2	Pressure Control
3	Outlet Valve
4	Fitting
5	Strainer
6	Manifold Filter
7	Pump
9	Grate
10	Prime Valve
11	Tire
32	Hose

# Component Identification

HS 6495

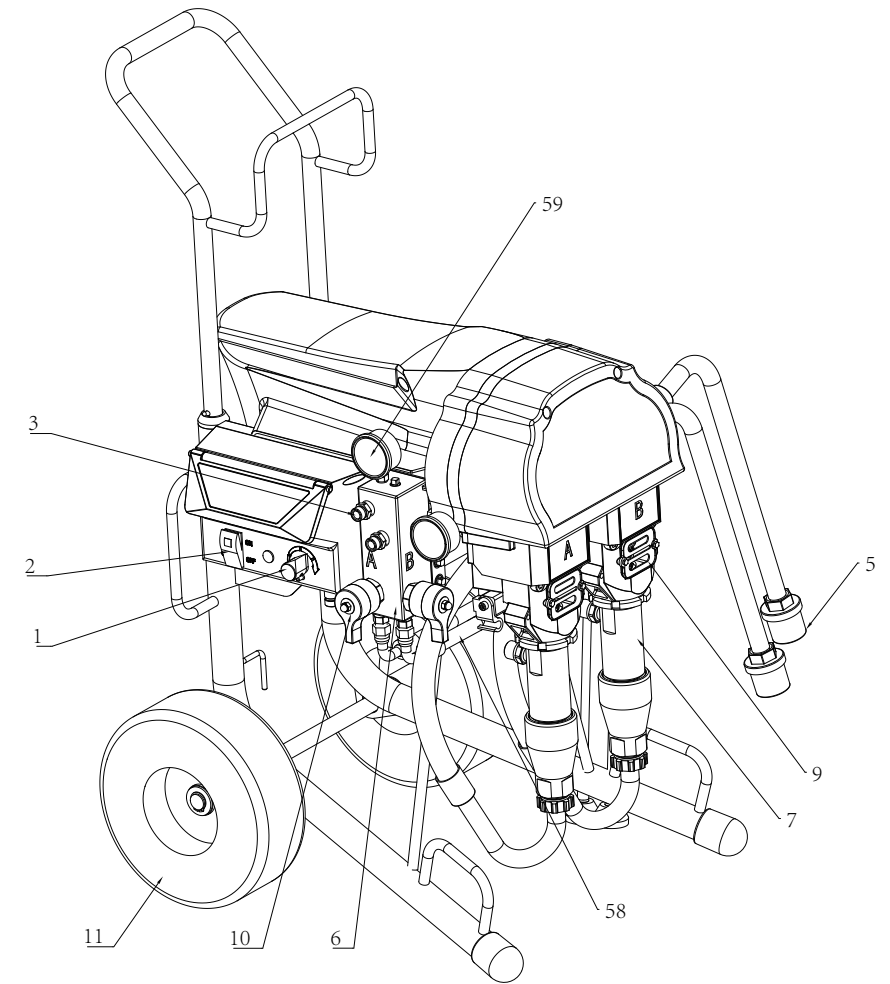

NO	Name
1	Pressure Control
2	Power Switch
3	Outlet Valve A/B
5	Strainer A/B
6	Manifold
7	Pump A/B
9	Grate
10	Prime Valve A/B
11	Tire
58	Suction Tube A/B
59	Pressure Gauge A/B

## Grounding



This equipment must be grounded to reduce the risk of static sparks and electric shock. Electric sparks or static electricity may ignite gases or cause explosions. Improper grounding can lead to electric shock. Grounding provides an escape path for electrical current.

The spray machine's power cord is equipped with a grounding wire and appropriate grounding prongs. Do not use the spray machine if the grounding prong on the cord is damaged.

The plug must be inserted into a power outlet that is properly installed and grounded in accordance with local regulations and requirements.

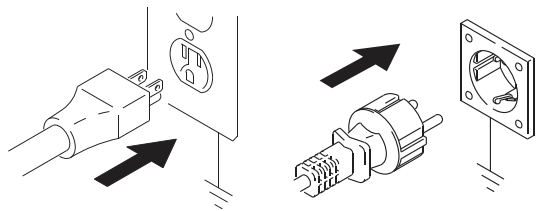

Do not modify the plug! If it cannot be inserted into the power outlet, have a qualified electrician reinstall a grounded power outlet. Do not use an adapter.

## Power Requirements

- The 230V device requires a 220–240V, 50/60 Hz, 10–16 amp AC power supply.

## Extension Cord

Use an extension cord with an undamaged grounding prong. If an extension cord is necessary, it should be at least a 3-core (4 mm<sup>2</sup>) wire. Using a cord that is too long or of a lower specification than (4 mm<sup>2</sup>) may affect the performance of the spray machine.

## Bucket

For solvents and oil-based fluids: Follow local regulations. Only use conductive metal buckets placed on grounded surfaces (such as concrete). Do not place buckets on non-conductive surfaces like paper or cardboard, as these surfaces can affect grounding continuity.

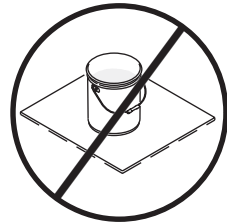

Grounding the Metal Bucket: Attach one end of a grounding wire securely to the bucket and connect the other end to a true grounding point, effectively grounding the bucket.

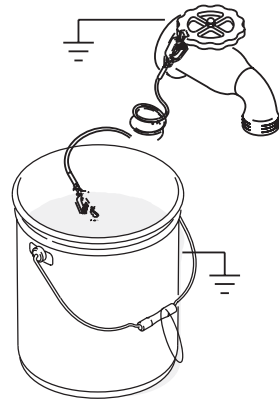

Maintain Grounding Continuity When Flushing or Releasing Pressure: Keep the metal part of the spray gun securely against the edge of the grounded metal bucket. Then, pull the trigger on the spray gun.



## Pressure Relief Procedure



When you see this symbol, please perform the pressure relief procedure.



This equipment remains pressurized until manually relieving the pressure. To prevent serious injuries from pressurized fluids (such as injection into the skin, fluid splashes, and moving parts), please follow the pressure relief steps before stopping spraying and before cleaning, inspecting, or servicing the equipment.

1. Turn off the power. Wait 7 seconds to allow power dissipation.

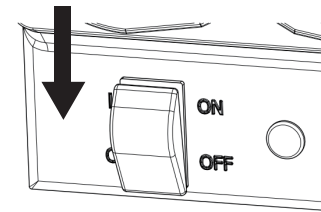

2. Lock the spray gun.

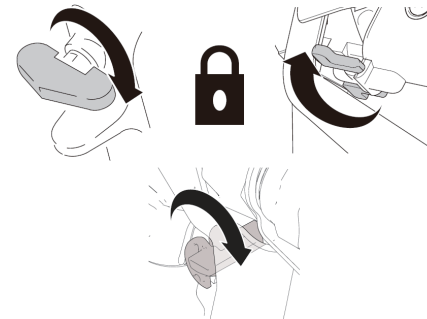

3. Remove the guard and nozzle.

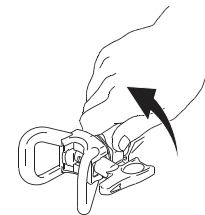

4. Set the pressure to the minimum. Unlock the spray gun, pull the trigger to release the pressure.

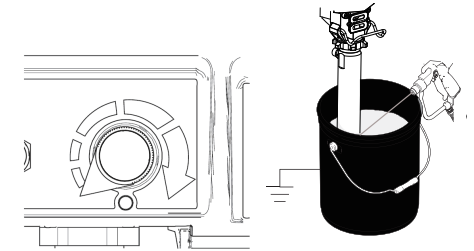

5. Place the return hose into the bucket. Rotate the prime valve down to the "Prime" position. Keep the pressure relief valve in the "Prime" position until ready to spray again.

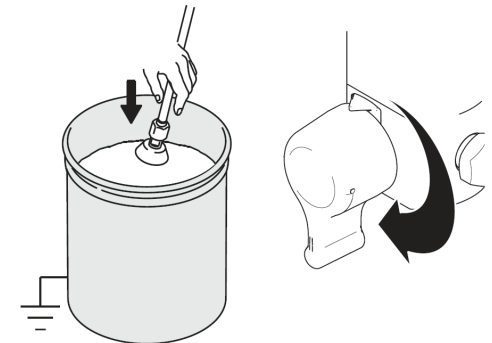

6. If there is suspicion of a clogged nozzle or hose, or if it seems the pressure has not fully relieved after the above steps, slowly loosen the securing nut on the nozzle guard or the connection at the end of the hose to gradually relieve pressure before fully removing it. Clean any blockages in the hose or nozzle.

## Setup/Installation



1. Connect the high-pressure hose to the spraying machine and tighten it firmly.

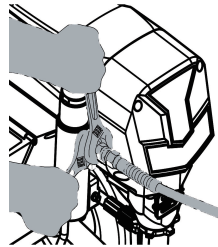

2. Connect other end of hose to gun. Tighten securely.

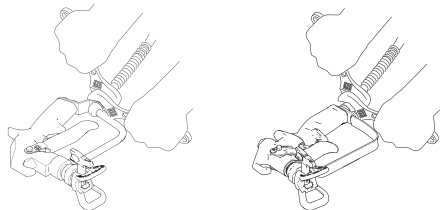

3. Engage gun trigger lock.



4. Remove tip guard.

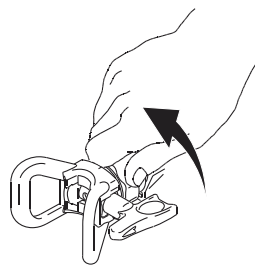

5. Check the pump inlet for blockages and debris; ensure the ball is not stuck.

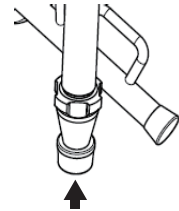

6. Fill the pump packing nut with sealing lubricant to prevent premature wear of the seals. This should be done before each spraying operation.

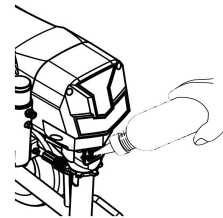

7. Turn off the power.

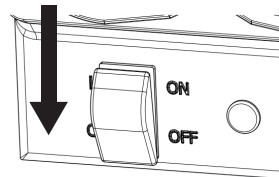

8. Insert the power cord plug into a properly grounded power outlet.
9. Rotate the prime valve down to the "Prime Position."
10. Place the pump into a grounded metal bucket partially filled with cleaning materials. Connect the bucket to a true grounding point with a grounding wire. Follow steps 1 to 5 on page 8 to flush out the oil stored in the spray machine. Rinse with water for water-based coatings and use mineral spirits to clean oil-based coatings and stored oil.

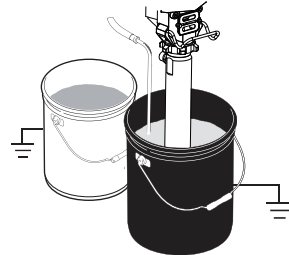

## Starting



1. Perform the pressure relief procedure (see page 6).
2. Rotate the pressure control knob to the lowest pressure.

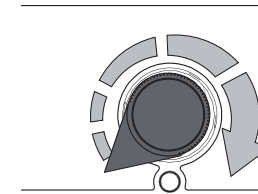

3. Turn on the power.

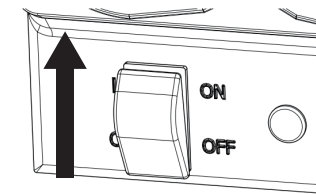

4. Increase the pressure by half a turn to start the motor, then let it circulate through the return hose for 15 seconds to reduce the pressure.



15sec.



5. Rotate the prime valve to the "Spray Position" and release the spray gun trigger lock.

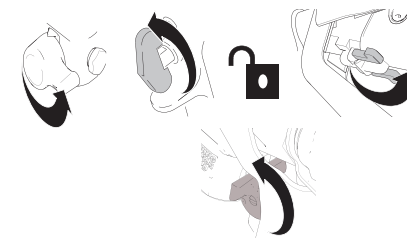

6. Hold the spray gun against the grounded metal cleaning bucket and pull the trigger, increasing the fluid pressure by half a turn. Flush for 1 minute.

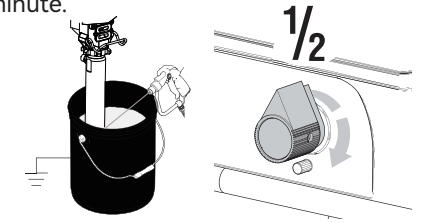

7. Check for leaks. If there are leaks, perform the pressure relief procedure. Tighten the leaking part or replace the leaking components, then repeat steps 1 to 5 of the starting procedure. If there are no leaks, proceed to step 8.

8. Place the pump into the paint bucket.

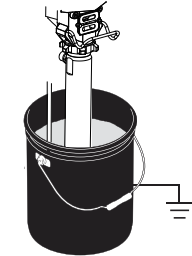

9. Pull the trigger again into the cleaning bucket until paint flows out. Move the spray gun to the paint bucket and pull the trigger for 20 seconds.

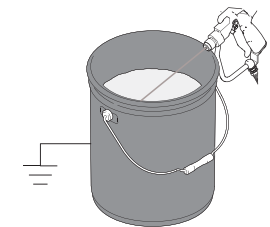

10. Lock the trigger. Follow the instructions on the next page to assemble the nozzle and guard.

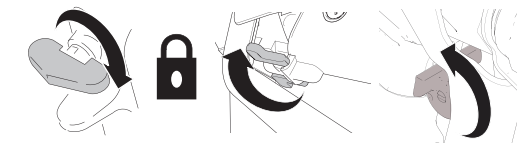

## Assemble tip and guard



1. Relief pressure, page 6
2. Insert the saddle (B) into the nozzle seat (C).

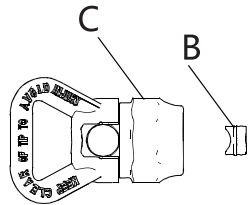

3. Insert Switch tip.

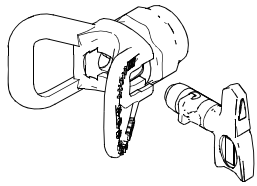

4. Screw assembly onto gun. Tighten.

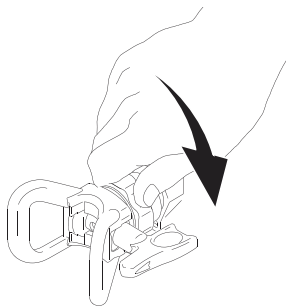

## Spraying

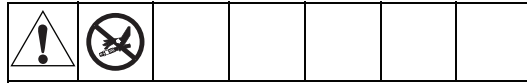

High-pressure spraying can inject toxic substances into the body, leading to serious physical harm. Do not use objects or rags to block leaks.

1. Test the spray pattern. Increase the pressure to eliminate the track. If adjusting the pressure does not eliminate the track, a smaller nozzle may be used.

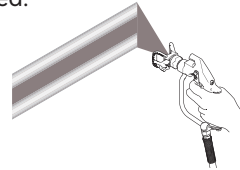

2. Hold the spray gun vertically, keeping it 10-12 inches (25-30 cm) from the surface being sprayed. Spray back and forth with 50% overlap, pulling the trigger after moving the spray gun and releasing it before stopping.

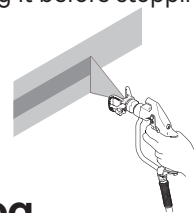

## Clear Clog



Skin injections are dangerous, do not point the spray gun towards your hands or a cloth!

1. Release the trigger and lock the trigger lock. Rotate the nozzle 180 ° and release the trigger Lock and pull the spray gun to clean any blockages.

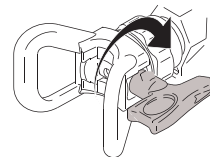

2. Lock the trigger lock and rotate the nozzle to its original position. Release the trigger lock, Continue spraying.

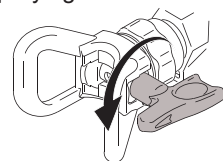

## Cleanup



1. Follow the pressure relief procedure (Steps 1-4 on page 6). Remove the guard from the spray gun.

NOTE: Use water for water-based coatings and mineral spirits or other solvents recommended by the manufacturer for oil-based coatings.

2. Turn power ON. Turn prime valve horizontal.

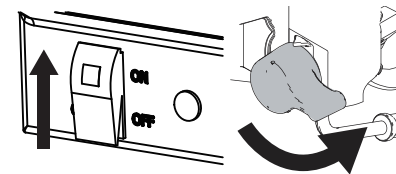

3. Increase pressure to 1/2, Hold gun against paint pail. Take trigger safety OFF. Trigger gun until flushing fluid appears.

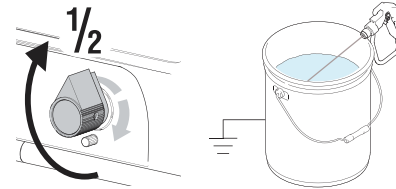

4. Move gun to wastepail, hold gun against pail, trigger gun to thoroughly flush system. Release the trigger and lock the trigger lock.

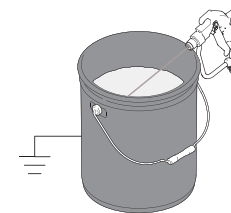

5. Rotate the prime valve to the "Prime" position to circulate and flush the fluid until clean flushing fluid appears.

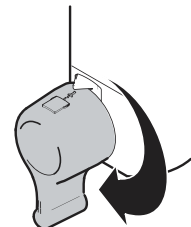

6. Rotate the pressure relief valve to the "spray" position and trigger the gun into the flush bucket to drain fluid from the hose.

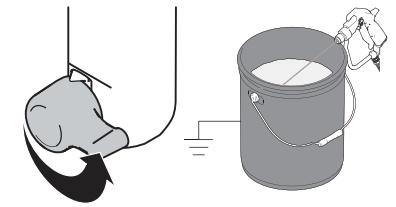

7. Raise the suction tube above the flush level and run the sprayer for 15 to 30 seconds to drain the fluid and turn off the power.
8. Open prime valve. Unplug sprayer.

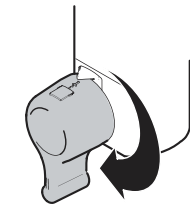

9. Remove filter from gun and sprayer, if installed. Clean and inspect. Install filters.

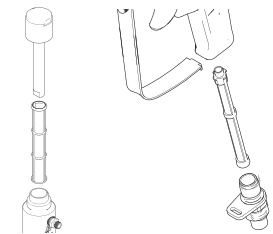

10. If flushing with water, flush again with mineral spirits, or Pump Armor, to leave a protective coating to prevent freezing or corrosion.

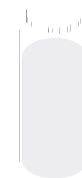

11. Wipe sprayer, hose and gun with a rag soaked in water or mineral spirits.



# Digital Tracking System

HS 1095/1195/1195HD/1395HD/1595HD/6495

## Operation Main Menu

1. Turn pressure to lowest setting. Trigger gun to relieve pressure. Turn prime valve down to DRAIN position.

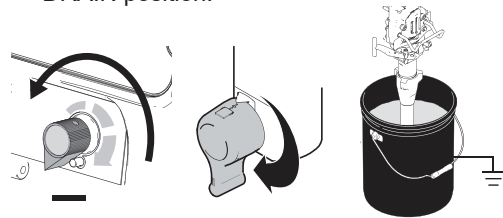

2. Press the button to switch to the PSI unit display; the display shows 3300 PSI.

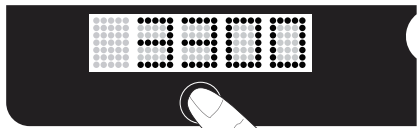

3. Press the button again to show the motor's operating time; the display indicates 8 hours of usage.

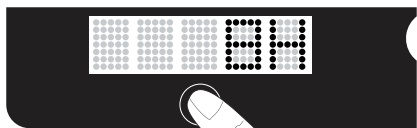

4. Press the button again to display the motor temperature; the display shows a temperature of 30 degrees Celsius.

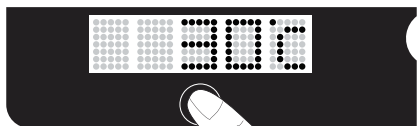

5. Press the button once more to switch the pressure unit to bar; the display shows 230 bar.

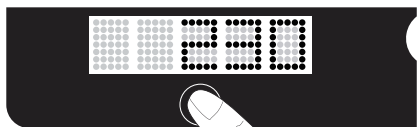

# Control Board Replacement

## Removal



Follow the pressure relief steps on page 6:

1. Remove the cover of the electrical control box: unscrew the 4 screws.
2. Disconnect the potentiometer plug, the display plug, and the two red ON/OFF power input connectors.
3. Disconnect the sensor connector.
4. Use a Phillips screwdriver to loosen the motor connection wires; the order of the connection wires is yellow, green, blue.
5. Remove the 6 screws from the circuit board.

## Installation



1. Use acetone or similar cleanser to clean sweep thermal compound from shaded component areas on rear of motor control board.

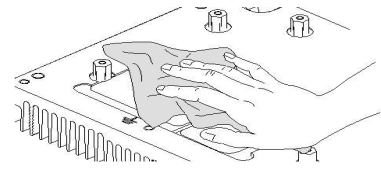

2. Apply small amount of thermal compound to shaded component areas on rear of motor control board.

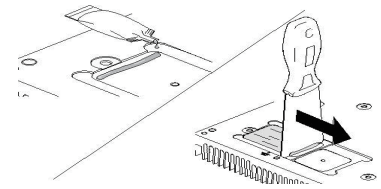

3. Reinstall the 6 internal screws onto the control board and tighten them with a 17-inch-lb (1Nm) torque wrench. Reassemble the remaining components in the reverse order of disassembly.

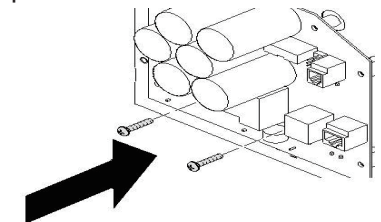

# Removing the Drive Housing

## NOTE

When removing the drive housing (53), ensure the gear set does not fall out. The gear set can remain in the cavity of the motor base or inside the drive housing.

## Disassembly



Follow the pressure relief procedure on page 6.

1. Remove bolt (11) to take off the front cover (12).
2. Remove bolt (21) to take off the rear cover (22).
3. Remove bolt (8) to take off the pump grate (9).
4. Remove the pump (7); see page 14 for the replacement procedure.
5. Remove bolt (14) to take off the housing (19) and connecting rod (54).
6. Remove bolt (13) to take off the drive housing (53), completing the disassembly.

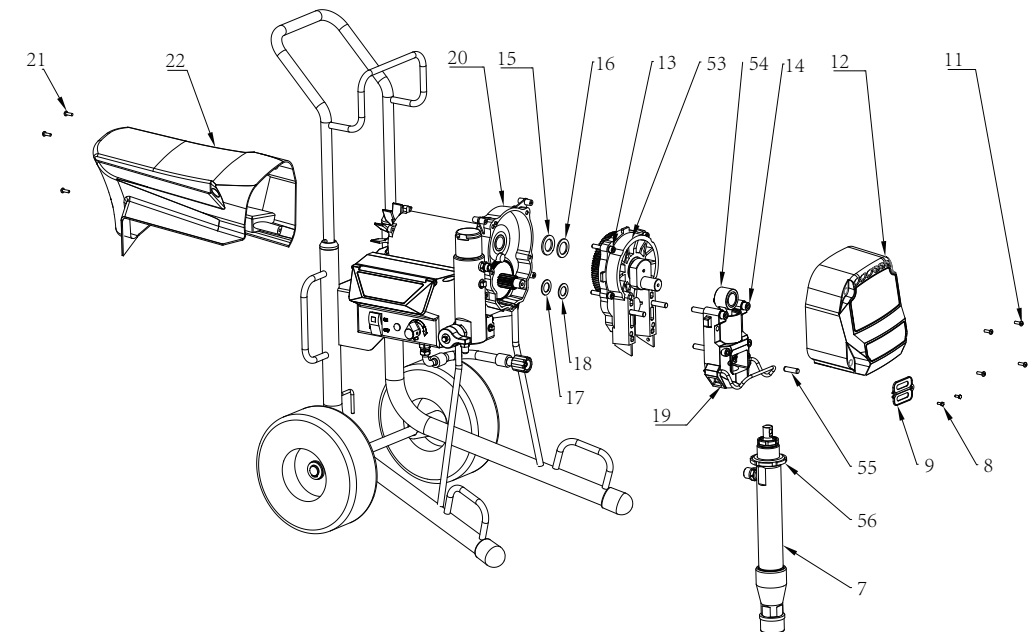

## Installation



Ensure the gears and thrust washers (15, 16, 17, 18) are correctly installed and in place. Apply grease to the gear tooth.

1. Align the drive housing (53) with the motor housing (20) and tighten bolt (13).
2. Align the housing (19) and connecting rod (54) with the drive housing (53), then tighten bolt (14).
3. Install the pump (7); refer to page 14 for the replacement procedure.
4. Align the pump grate (9) with the installation holes of the housing (19) and tighten bolt (8).
5. Install the front cover (12) and tighten bolt (11).
6. Install the rear cover (22) and tighten bolt (21) to complete the installation.

# Replacing the Motor

## Disassembly



Follow the pressure relief procedure on page 6.

1. Remove bolt (21) and take off the rear cover (22).
2. Remove bolt (11) and take off the front cover (12).
3. Unscrew bolt (14) that secures the housing (19) and remove the housing along with the connecting rod (54).
4. Unscrew bolt (13) to detach the drive housing (53).
5. Remove bolt (26) to take off the control box (27) and disconnect the motor (25) from the circuit board.
6. Remove the cooling fan (23).
7. Unscrew nut (29) to extract bolt (28), allowing the motor (25) to be removed.

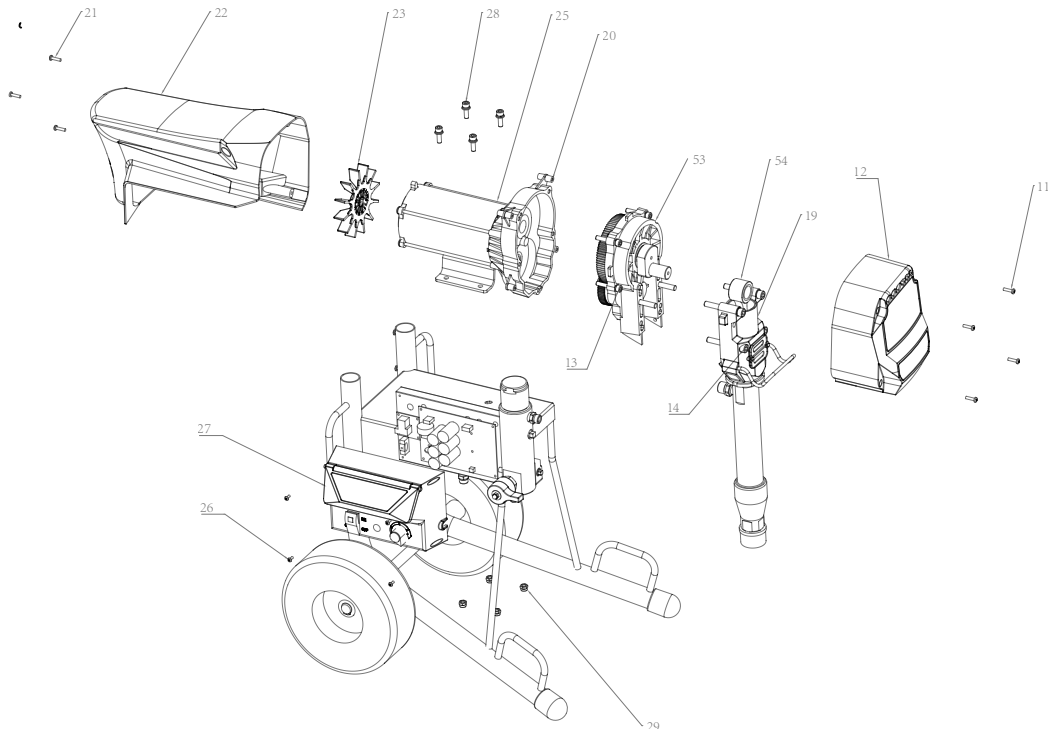

## Installation



1. Place the new motor (25) onto the frame, aligning it with the frame holes, and insert bolt (28) through the motor (25) into the frame.
2. Tighten nut (29) onto bolt (28).
3. Install the cooling fan (23) onto the end of the motor (25) shaft.
4. Connect the motor (25) wiring to the circuit board, then cover the control box (27) and tighten bolt (26).
5. Align the mounting holes of the drive housing (53) with the motor base (20), then close them and tighten bolt (13).
6. Align the connecting rod (54) with the connecting rod shaft inside the drive housing (53), close the housing (19), and tighten bolt (14).
7. Place the front cover (12) on and tighten bolt (11).
8. Place the rear cover (22) on and tighten bolt (21), completing the motor installation.

# Replacing the Piston Pump

## NOTE

If the anti-loosening nut (56) on the pump becomes loose during operation, it may damage the threads of the drive housing (53).

## Removal



1. Flush pump
2. Relieve pressure, page 6.
3. Remove screws (8), slid pump rod shield left (9).

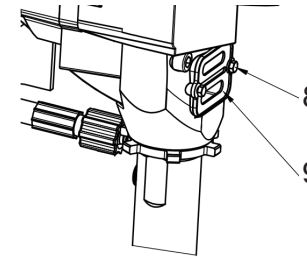

4. Slowly rotate the pressure control knob clockwise to allow the motor to run slowly, observing the piston rod pin (44) in the removable position. Turn off the power switch and unplug the power cord. Push the retaining spring (43) upward and use a screwdriver to push out the piston rod pin (44).

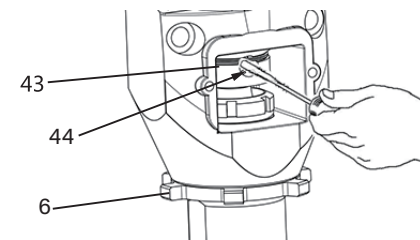

5. Remove the connecting hose (32).
6. Use a hammer to loosen the lock nut (56) of the pump, and then unscrew the pump.

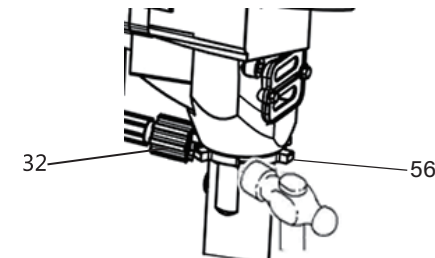

## Installation



If pump pin works loose, parts could break off due to force of pumping action. Parts could project through the air and result in serious injury or property damage.

1. Extend the piston rod by 40mm, then rotate the pump to align the piston rod hole with the piston pin hole.
2. Install the piston rod pin. Ensure the locking spring is positioned within the groove of the connecting rod.
3. Push the pump upward until the pump threads engage.
4. Screw the pump in until the end of the pump threads is close to the bottom of the pump body, aligning the pump outlet backward.

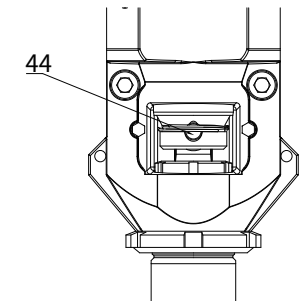

5. Connect the connection hose (32).
6. Screw the anti-loosening nut (6) on the pump upward until it cannot be turned further. Tighten the nut by hand, then use a 0.5 kg (maximum) hammer to tap it an additional 1/8 to 1/4 turn, achieving approximately 102 Nm of torque.
7. Install the pump grate (9) using screws (8).
8. Apply 5-6 drops of throat seal lubricant to the sealing nut.

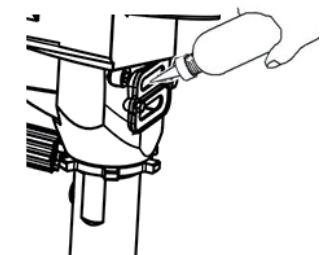

# Troubleshooting



CAUTION	
Never increase fluid pressure in the sprayer without the sensor installed. If using a test sensor, ensure the prime valve at the prime position.	

Relief pressure,page 6.

Type of Problem	Problem Manifestation	What to Check (if check is OK,go to next)	WHAT TO DO (When check is not OK, to this refr coulumn)
<b>No fluid supply</b>	There is no fluid supply,until trigger spray gun for a while.	Inlet valve and ball stick together or outlet valve and ball stick together.	Use the screwdriver to top up the ball.
		The prime valve is blocked, preventing the machine from discharging air properly.	Clean and maintain the prime valve.
Low pressure		Spray tip worn,or spray size is not suitable.	Relieve pressure, Repair the tip.
		Use a multimeter to check if the voltage is too low.	Use the normal pressure.
		The fluid is not enough.	Add more fluid into the pail.
		Ensure that the extension cord is appropriate. It should be at least a 3-core (4 mm <sup>2</sup> ) wire; using a cord that is too long or of a lower gauge than (4 mm <sup>2</sup> ) will affect the performance of the sprayer.	Replace with a correct, grounded,extension cord.
<b>Low Output</b>	Stop painting, but the pump is still stroke	Check whether there is any other matter stuck on the piston valve and the ball seat, or the paint has hardened.	Clean the inlet valve and outlet valve.
		Inlet valve and outlet valve worn	Replace inlet valve and outlet valve.
		Severe damage of ball seat and piston valve.	Replace the ball seat and piston valve ball.
		Check if the piston gasket and seal worn seriously.	Replace the piston gasket seal.
		Worn of the piston rod.	Replace piston rod.
		Check if there is paint oozing from the pump locking nut.	Replace packings.
		If the prime valve is leaking (making a hissing sound)	Relieve pressure. Repair prime valve.
		The maximum pressure value showe on the LCD display is over 22.7Mpa.	Repace the transsducer.
	The working power is less than the pressure shown on LCD display.	Gun filter is clogged.	Clean gun filter,and replace if necessary.
		Spray tip is clogged.	Relieve pressure.clean tip.
Manifold filter clogged.		Clean manifold filter,and replace if necessary.	
The value shows on pressure gauge is different from LCD display.		Repace the transsducer.	

Type of Problem	Problem Manifestation	What to Check (if check is OK,go to next)	WHAT TO DO (When check is not OK, to this refr coulumn)
<b>Motor runs but pump does not stroke.</b>	When machine start work, the connecting rod is run normal,but piston rod is not in working.	Piston pin is damaged or missing.	Replace the piston pin if necessary.ensure the retainer spring is fully in groove all around connecting rod.
	The connecting rod assembly (plunger rod) is not working,and the eccentric shaft is working.	Connecting rod assembly is damaged.	Replace connecting. rod assembly.
	Eccentric shaft is not working.	Gears or drive housing.	Inspect drive housing assembly and gears for damage and replace if necessary.
<b>Sprayer Switch On The circuit breaker in the building trips.</b>	Sprayer Switch Off: Circuit breaker trips.	Power Cord or Extension Cord Short Circuit.	Check or Replace.
	Sprayer Operates for a While: Circuit breaker trips.	Check if the corridor circuit breaker is greater than 16A.	Ensure power cord is connected to a circuit breaker greater than 16A
		ON/OFF Power Switch Failure.	Replace ON/OFF power switch.
		Circuit Board Failure.	Replace circuit board.
		Sensor Failure.	Replace sensor.
	Sprayer Operates for a While: Circuit breaker trips.	Motor Failure.	Recommended to return for testing and repair
<b>Sprayer quit after sprayer operates for a while.</b>	Machine is suddenly quit, but rest for a while, the machine is restart.	The sprayer has been running continuously for too long time,the motor has overheated,and the circuit board has activated thermal protection.	Stop the working,after self-cooling,then continue work.

## Motor Control Board Diagnostics



### NOTE:

- Keep a new transducer on hand to use for test.
- No display does not mean the sprayer is not pressurized. Before repair,relieve pressure,page 6

<b>CAUTION</b>
Do not allow sprayer to develop fluid pressure without transducer installed.Leave drain valve open if test transducer is used.

1. For sprayers with digital display, see "Digital Display Information".
2. Turn ON the ON/OFF power switch.

DISPLAYLED	NIXIE DISPLAY	WHAT TO DO
No display		
psi/bar/MPa	The spraying machine has been pressurized. The power is turned on.	
E=01	IPM temperature high (4KW)	Clean the dirt from the heat sink and wait for the drive to cool down before returning to normal.
E=02	Communication failure	Check the communication connection signal line between the sensor board and the motor drive,if there is no fault with the signal line, it should be repaired by the manufacturer instead.
E=03	Sensor failure	Check if the sensor has poor contact or replace it.
E=04	Connection or mechanical failure between motor and drive controller.	Check the connection between the motor and driver, and check if the machinery is stuck. After confirming that everything is normal Replace the driver for testing, identify motor or driver faults, and then repair the corresponding components!
E=05	Motor or driver overcurrent fault	Same as E-04.
E=06	IPM alarm	Same as E-05.
E=07	Pressure larger than 7Mpa under cleaning status	Turn on the spray gun or adjust the pressure control potentiometer to the normal position!
E=08	Power supply undervoltage	Check if the power supply voltage or socket is faulty!
E=10	Motor overheating temperature protection.	
E=11	Power input protection	Check if the power supply is connected to AC380V or if there is a problem with the input power supply. After solving the problem, Wait until the machine is fully discharged (usually when the display screen goes out, it means it has been discharged), then turn on machine for use.

## Electric

Symptoms: The sprayer fails to operate, stops unexpectedly, or cannot shut down.  
Perform the pressure relief procedure (see page 6).



1. Ensure sprayer is plugged into a correct grounded power outlet
2. Set the power switch as 30 seconds re-start after power shortage. This can ensure the sprayer is in normal operating mode.
3. Rotate the pressure control knob clockwise by 1/2 turn.
4. Check the digital display.



Avoid contact with electrical components and moving parts during troubleshooting.  
To prevent electric shock, wait 5 minutes after unplugging before removing the outer cover to allow accumulated charge to dissipate.

## Technical Data

MODEL	HS1095	HS1195 HS1195HD	HS1395HD	HS1595HD	HS6495
Maximum Flow	4L/Min	6L/Min	7.6L/Min	9L/Min	10L/Min
Maximum Tip Size	0.031	0.035	0.041	0.045	0.027x2
Hose Connector	3/8inch	3/8inch	3/8inch	3/8inch	3/8inch
Power	2600W	3000W	4000W	4500W	4000W
Voltage, Current, Hertz	220V,15A,50Hz	220V,15A,50Hz	220V,20A,50Hz	220V,22A,50Hz	220V,20A,50Hz
Net Weight	50.7KG	50.7KG	54.7KG	61KG	71.7KG
Box Rule	70cmx56cmx87cm	70cmx56cmx87cm	70cmx56cmx87cm	70cmx60cmx87cm	70cmx56cmx87cm
Noise (measured at 1 meter according to ISO 3744 requirements)	83 dB	83 dB	85 dB	85 dB	85 dB

# 1095 Pump assembly

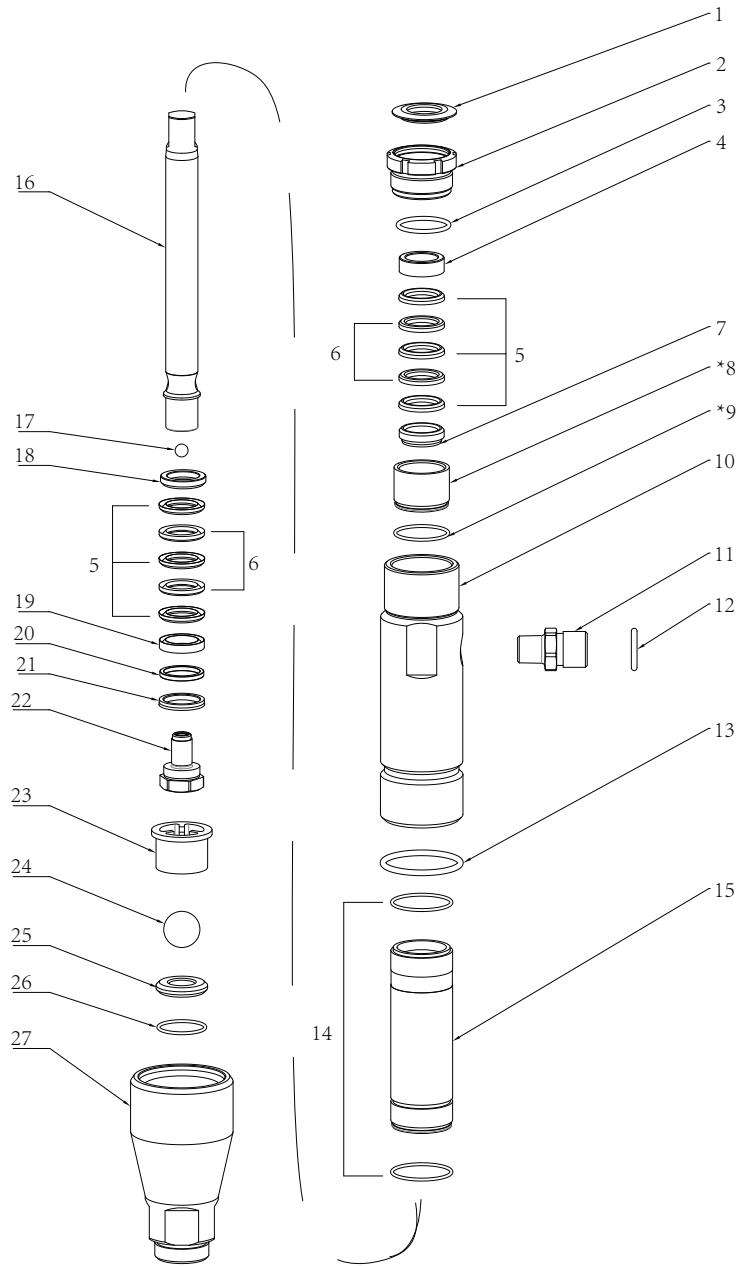

## 1195/1195HD Extended pump assembly

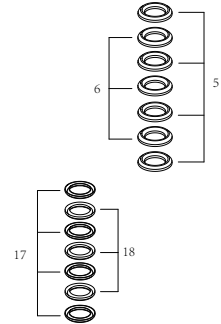

NO	Name	Quantity
5	V-packing	4
6	Leather V-ring	3
17	V-packing	4
18	Leather V-ring	3

NO	Name	Quantity
1	Seal,throat	1
2	Nut,packing	1
3	oring	1
4	GLAND, female, throat	1
5	V-packing	6
6	Leather V-ring	4
7	GLAND, male, throat	1
*8	Upper sealing sleeve (350 only)	1
*9	PTFE O-ring (350 only)	1
10	Cylinder	1
11	Cylinder Screw	1
12	oring	1
13	oring	1
14	PTFE O-ring	2
15	Inner cylinder liner	1
16	Piston Rod	1
17	Tungsten steel ball	1
18	GLAND, male, piston	1
19	GLAND, female, piston	1
20	WIPER, piston	1
21	WASHER, backup	1
22	Piston valve	1
23	Ball guide	1
24	Tungsten steel ball	1
25	Inlet valve seat	1
26	PTFE O-ring	1
27	Intake housing	1

# 1395HD /1595HD Pump assembly

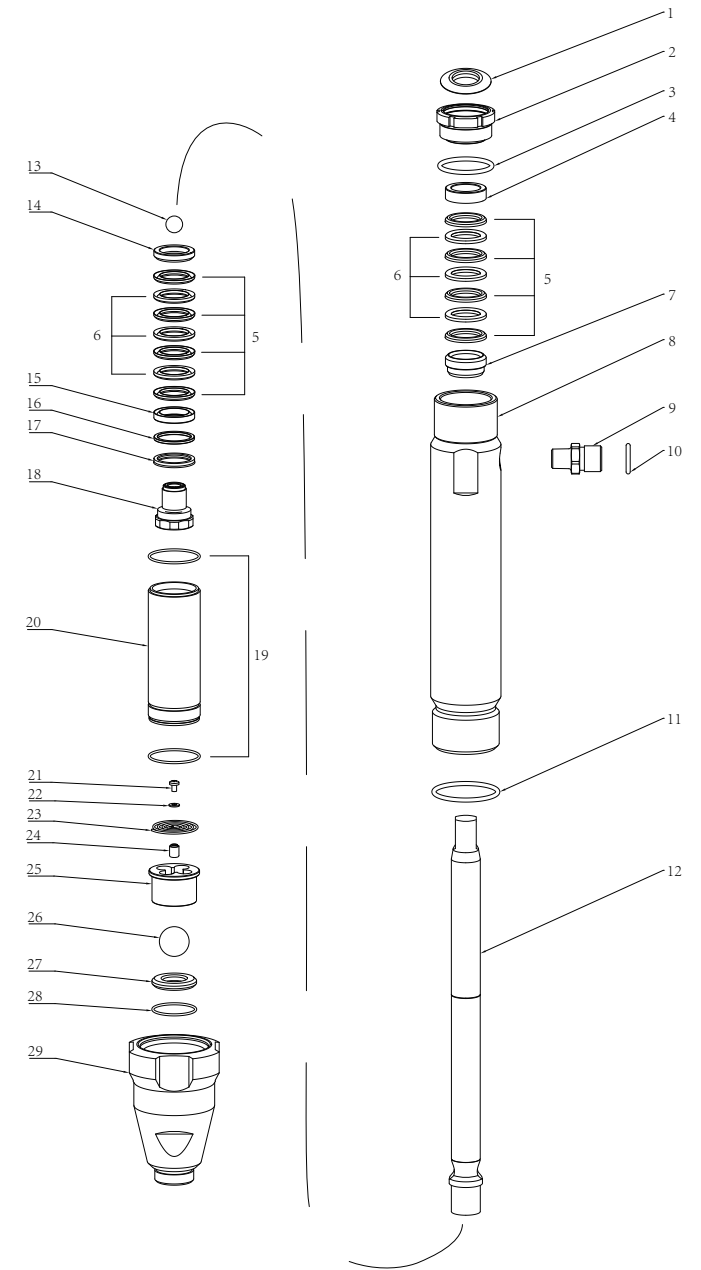

NO	Name	Quantity
1	Seal,throat	1
2	Nut,packing	1
3	oring	1
4	GLAND, female, throat	1
5	V-packing	8
6	Leather V-ring	6
7	GLAND, male, throat	1
8	Cylinder	1
9	Cylinder Screw	1
10	oring	1
11	oring	1
12	Piston Rod	1
13	Tungsten steel ball	1
14	GLAND, male, piston	1
15	GLAND, female, piston	1
16	WIPER, piston	1
17	WASHER, backup	1
18	Piston valve	1
19	PTFE O-ring	2
20	Sleeve,cylinder	1
21	Bolt	1
22	Flat mat	1
23	Ball positioning spring	1
24	Limit nut	1
25	Ball guide	1
26	Tungsten steel ball	1
27	Inlet valve seat	1
28	PTFE O-ring	1
29	Intake housing	1