

# User Manual

## HB3400/3400II/5900



### Airless Line Striper

For the application of line striping materials. For professional use only. For outdoor use only.  
Not approved for use in explosive atmospheres or hazardous locations.



#### Important Safety Instructions

Read all warnings and instructions in this manual, related manuals, and on the equipment. Be familiar with the controls and the proper usage of the equipment. Save these instructions.

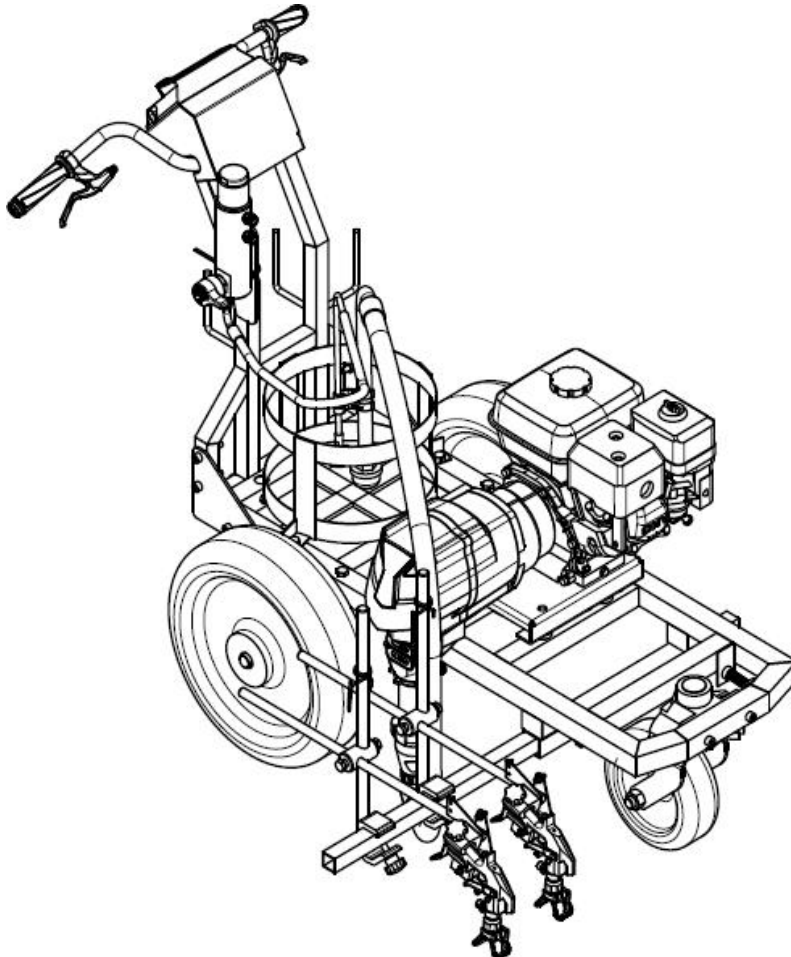



# Warning

The following warnings include general safety information for this equipment.

"!" means general warnings, while other warning symbols means danger what associated with specific operating procedures.

When the symbols appear in the manual or the warning, please refer back.

Further product specific warnings may be included in the text where applicable

## Warning

### INJECTION HAZARD



- High pressure fluid from gun, hose leaks, or ruptured components will pierce skin. This may look like just a cut, but it is a serious injury that can result in amputation. Get immediate surgical treatment.
- Do not point the gun at anyone or at any part of the body.
- Do not stop or deflect leaks with your hand, body, glove or rag.
- Do not spray without tip guard and trigger guard installed.
- Follow Pressure Relief Procedure in this manual, when you stop spraying and before cleaning, checking or servicing equipment.
- Equipment still keep pressure after cutting off power. When unattended, do not leave the equipment in power or pressure.
- Check hoses, tubes, and couplings daily. Replace worn or damaged parts immediately
- Do not use components rated less than sprayer Maximum Working Pressure 3300PSI.
- Engage trigger lock when not spraying.
- Tighten all fluid connections before operating the equipment
- Keep know how to quickly shut down and pressure relief. Fully familiar with the control equipment







### FIRE AND EXPLOSION HAZARD



Flammable fumes, such as solvent and paint fumes, in work area can ignite or explode. To help prevent fire and explosion:

- Use only in an extremely well ventilated area.
- Do not fill fuel tank while engine is running or hot. should shut down the engine and makes it cooler.
- Eliminate all ignition sources; such as pilot lights, cigarettes and plastic drop cloths (static arc hazard).
- Ground equipment and conductive objects in work area. Read Grounding instructions
- Do not spray or clean solvent under high pressure.
- Keep work area free of debris, including solvent, rags, and gasoline
- Do not plug or unplug power cords or turn lights on or off when flammable fumes are present.
- Use only grounded hoses.
- Hold gun firmly to side of grounded pail when triggering into pail.
- If there is static sparking or you feel a shock, stop operation immediately. Do not use equipment until you identify and correct the problem.
- Keep effective fire extinguisher in work area.

## Warning

	<p><b>CARBON MONOXIDE HAZARD</b>  Exhaust contains poisonous carbon monoxide, which is colorless and odorless. Breathing carbon monoxide can cause death.</p> <ul style="list-style-type: none"> <li>• Do not operate in an enclosed area.</li> </ul>
	<p><b>BURN HAZARD</b>  Equipment surfaces and fluid that's heated can become very hot during operation. To avoid severe burns</p> <ul style="list-style-type: none"> <li>• Do not touch hot fluid or equipment.</li> </ul>
 	<p><b>EQUIPMENT MISUSE HAZARD</b>  Misuse can cause death or serious injury.</p> <ul style="list-style-type: none"> <li>• Do not use equipment when tired or drinking alcohol.</li> <li>• Do not exceed the maximum working pressure or temperature rating of the lowest rated system component. Read Technical Data in all equipment manuals.</li> <li>• Use fluids and solvents that are compatible with equipment wetted parts. Read Technical Data in all equipment manuals. Read fluid and solvent manufacturer's warnings. For complete information about your material, request MSDS from distributor or retailer.</li> <li>• Do not leave the equipment in power or pressure when unattended</li> <li>• Check equipment daily. Repair or replace worn or damaged parts immediately</li> <li>• Follow Pressure Relief Procedure in this manual, when you stop spraying</li> <li>• Check hoses, tubes, and couplings daily. Replace worn or damaged parts immediately</li> <li>• Do not alter or modify equipment. may lead to agency certification failure and cause safety hidden trouble</li> <li>• Ensure all equipment has been rated and certified and can available for your work area.</li> <li>• Use equipment only for its intended purpose. Call your distributor for information</li> <li>• Route hoses and cables away from traffic areas, sharp edges, moving parts, and hot surfaces.</li> <li>• Do not kink or overbend hoses or use hoses to pull equipment.</li> <li>• Keep children and animals away from work area.</li> <li>• Comply with all applicable safety regulations.</li> </ul>
	<p><b>PRESSURIZED ALUMINUM PARTS HAZARD</b></p> <ul style="list-style-type: none"> <li>• Do not use 1,1,1-trichloroethane, methylene chloride, and/or other halogenated hydrocarbon solvents or fluids containing such solvents in pressurized aluminum equipment. Such use can cause serious chemical reaction and equipment rupture, and result in death, serious injury, and/or property damage.</li> </ul>
 	<p><b>MOVING PARTS HAZARD</b>  Moving parts can pinch or amputate fingers and other body parts.</p> <ul style="list-style-type: none"> <li>• Keep clear of moving parts.</li> <li>• Do not operate equipment with protective guards or covers removed</li> <li>• Pressurized equipment can start without warning. Before checking, moving, or servicing equipment, follow the Pressure Relief Procedure in this manual. Disconnect power or air supply.</li> </ul>



## WARNING



### **TOXIC FLUID OR FUMES HAZARD**

Toxic fluids or fumes can cause serious injury or death if splashed in the eyes or on skin, inhaled, or swallowed.

- Read MSDS's to know the specific hazards of the fluids you are using.
- Store hazardous fluid in approved containers, and dispose of it according to applicable guidelines.



### **PERSONAL PROTECTIVE EQUIPMENT**

You must wear appropriate protective equipment when operating, servicing, or when in the operating area of the equipment to help protect you from serious injury, including eye injury, inhalation of toxic fumes, burns, and hearing loss. This equipment includes but is not limited to:

- Protective eyewear
- Clothing and respirator as recommended by the fluid and solvent manufacturer
- Gloves

# Component Identification

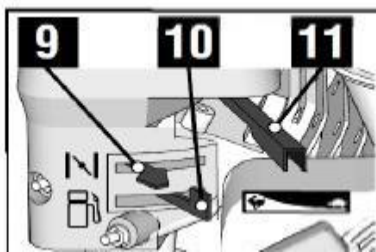
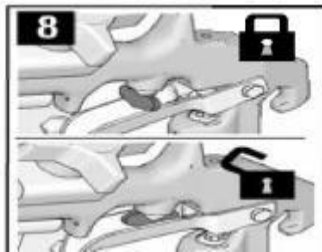
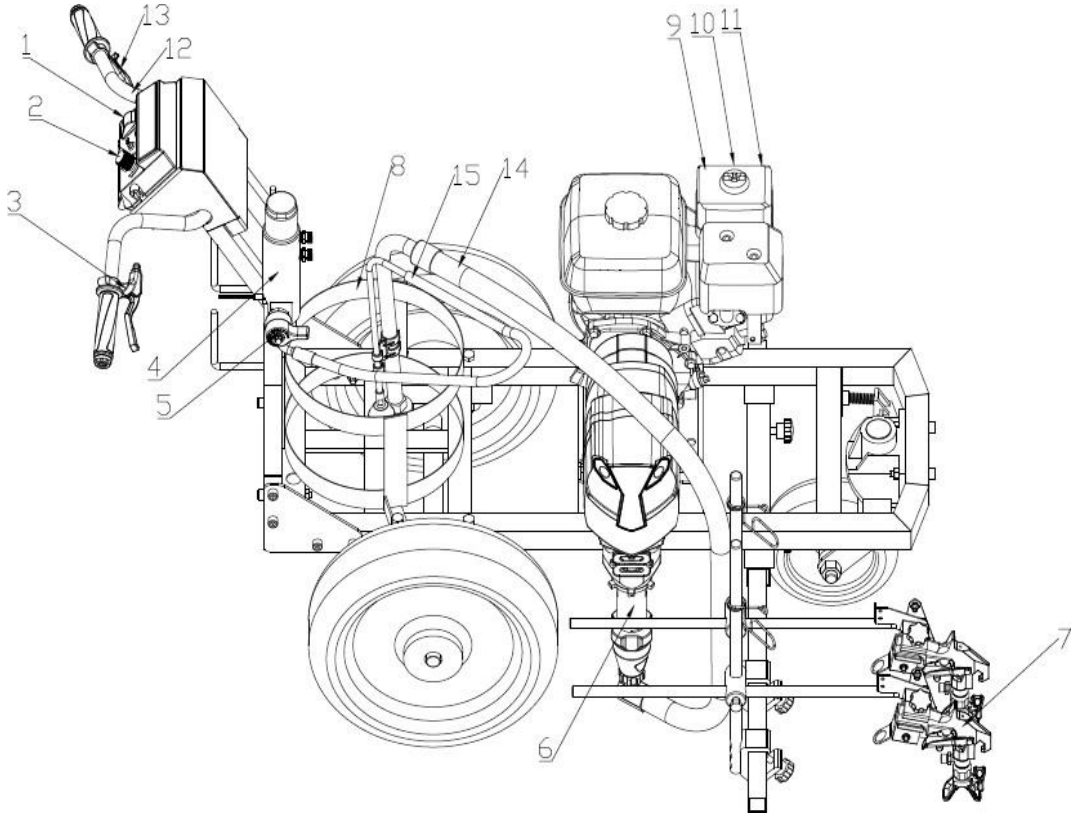

1	Pump ON/OFF switch
2	Pressure control
3	Spray gun trigger
4	Filter
5	Prime valve
6	Pump
7	Spray gun
8	Trigger Safety
9	Choke lever

10	Fuel valve
11	Throttle lever
12	Adjustable Handle
13	Front wheel unlock/lock
14	Suction tube
15	Drain hose

# Maintenance

DAILY: Check engine oil level and fill as necessary

DAILY: Check hose for wear and damage.

DAILY: Check gun safety for proper operation.

DAILY: Check pressure drain valve for proper operation.

DAILY: Check and fill the gas tank

DAILY: Check level of TSL in displacement pump packing nut. Fill out if necessary. Keep TSL in nut to help prevent fluid buildup on piston rod and premature wear of packings and pump corrosion.

## AFTER THE FIRST 20 HOURS OF OPERATION:

Drain engine oil and refill with clean oil. Reference Honda Engines Owner's Manual for correct oil viscosity.

WEEKLY: Remove engine air filter cover and clean element. Replace element, if necessary. If operating in an unusually dusty environment: check filter daily and replace. Filter replacements can be purchased from your local Honda dealer.

## if necessary AFTER EACH 100 HOURS OF OPERATION:

Change engine oil. Reference Honda Engines Owner's Manual for correct oil viscosity

SPARK PLUG: Use only BPR6ES (NGK) or W20EPR-U (NIPPONDENSO) plug.

Gap plug to 0.028 to 0.031 in (0.7 to 0.8 mm)

Use spark plug wrench when installing and removing plug.

# Wheel alignment

follow the wheel alignment Procedure in this manual

1. Loosen the screws(114)

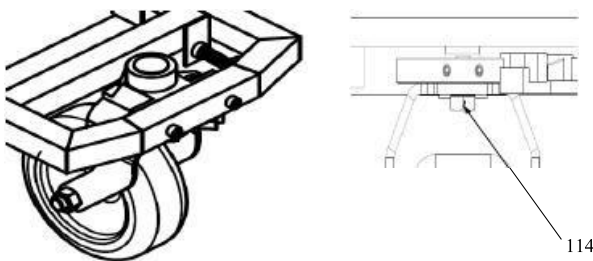

2. Place the front wheel on the one-side to the alignment.

3. Tighten the capscrew (114)

push and observation:

Let it slide by itself.

Repeat steps 1 and 2 until going along straight line.

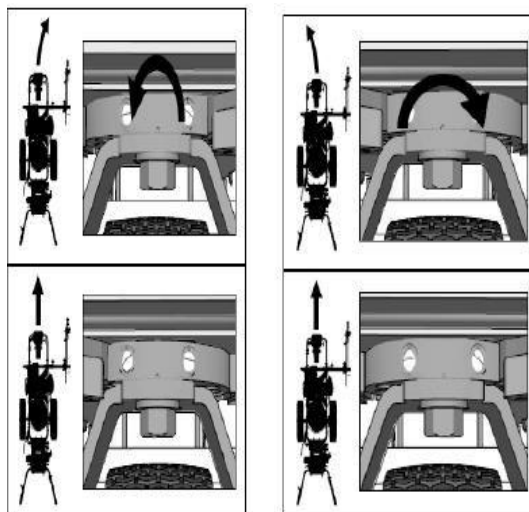

# Operation

## Setup

The equipment must be grounded to reduce the risk of static sparking. Static sparking can cause fumes to ignite or explode. Grounding provides an escape wire for the electric current.				

1. Ground striper with grounding clamp.

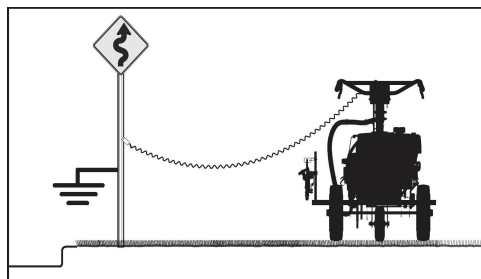

2. Fill throat packing nut with lubricating oil

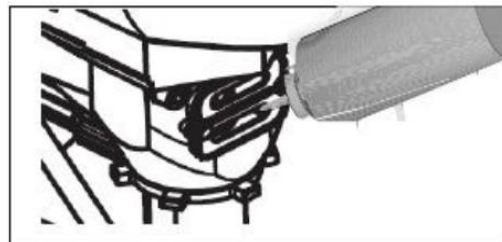

3. Check engine oil level. See Honda engine manual.

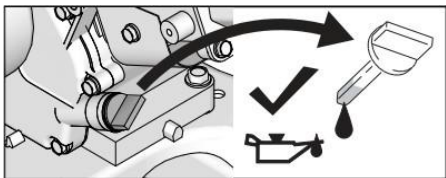

4. Fill fuel tank. See Honda engine manual. Check that tires are inflated to recommended pressure.

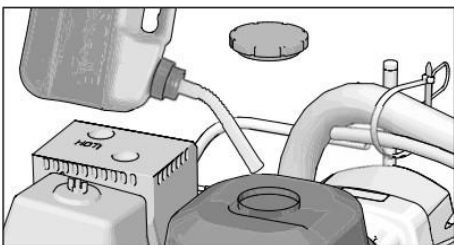

3. Turn prime valve down.

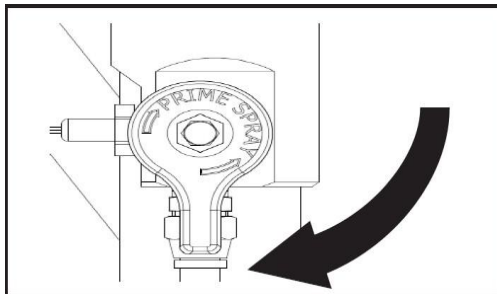

4. Turn pressure control counterclockwise to lowest pressure.



5. Set pump switch to OFF.

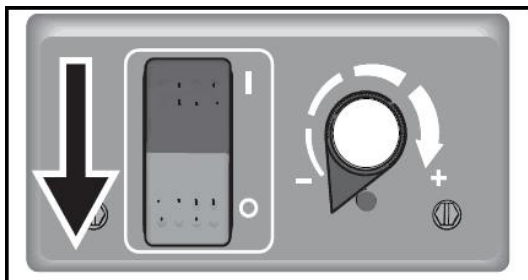

6. Start Engine.

a. Move fuel valve to open.

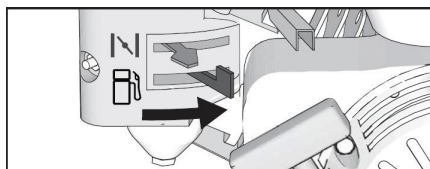

## Startup

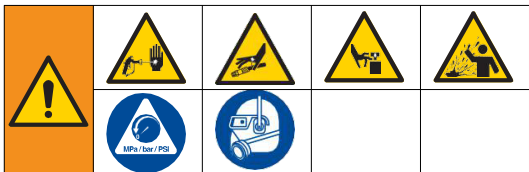

1. Perform Pressure Relief Procedure. See **Grounding Procedure (For Flammable Materials Only)**, page 5.

2. Place siphon tube set in grounded metal pail partially filled with flushing fluid. Attach ground wire to pail and to true earth ground. Use water to flush water-base paint and mineral spirits to flush oil-base paint and storage oil.

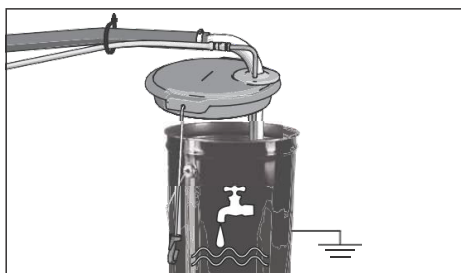

b. Move choke to closed.

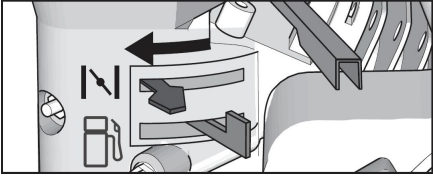

c. Set throttle to fast.

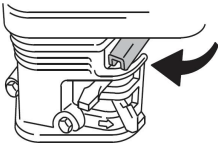

d. Set engine switch to ON.

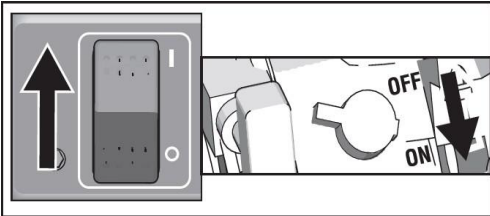

e. Pull starter cord.

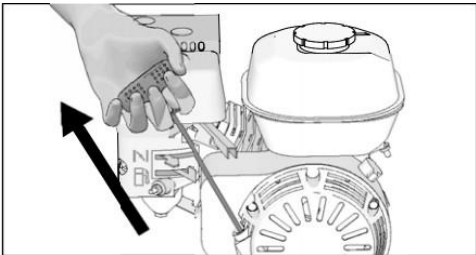

f. After engine starts, move choke to open.

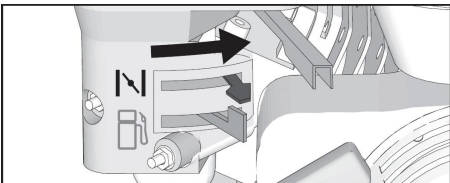

g. Set throttle to slow.

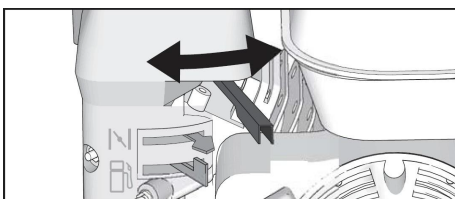

### NOTICE

Do not run pump without fluid flow. Damage to packings can occur.

7. Set pump switch to ON. Increase pressure enough to start pump. Allow fluid to circulate for 15 seconds.



8. Turn pressure down, close prime valve. Disengage gun trigger lock.

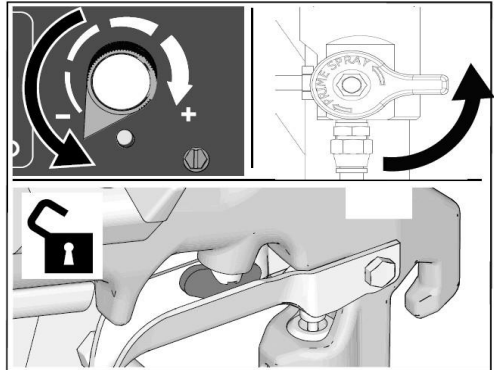

9. Hold gun against grounded metal flushing pail. Trigger gun and increase fluid pressure slowly until pump runs smoothly.

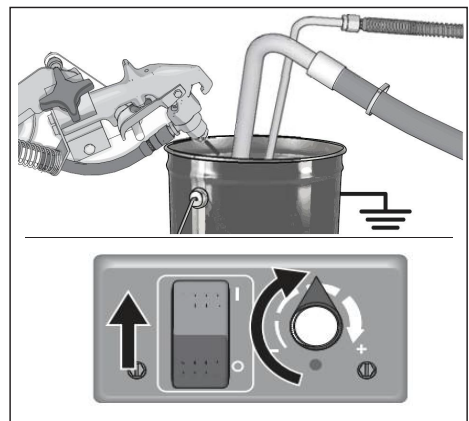



High-pressure spray is able to inject toxins into the body and cause serious bodily injury. Do not stop leaks with hand or rag.

10. Inspect fittings for leaks. Do not stop leaks with your hand or a rag! If leaks occur, turn striper OFF immediately. Perform **Grounding Procedure (For Flammable Materials Only)**, page 5. Tighten leaky fittings. Repeat **Startup**, steps 1 - 7. If no leaks, continue to trigger gun until system is thoroughly flushed. Proceed to step 8.
11. Place siphon tube in paint pail.

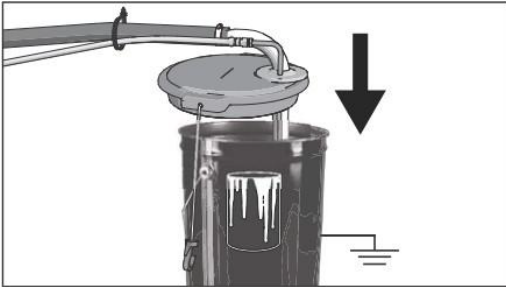

12. Trigger gun again into flushing fluid pail until paint appears. Assemble Tip and Guard.

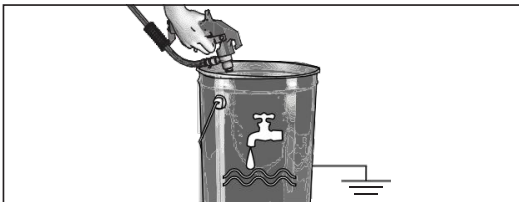

## Tip and Guard Assembly



To avoid serious injury from skin injection do not put your hand in front of the spray tip when installing or removing the spray tip and tip guard.

To prevent spray tip leaks, make certain spray tip and tip guard are installed properly.

1. Perform **Pressure Relief Procedure**, page 5.
2. Engage trigger lock. Insert seat and Tip Seal. Insert Tip.

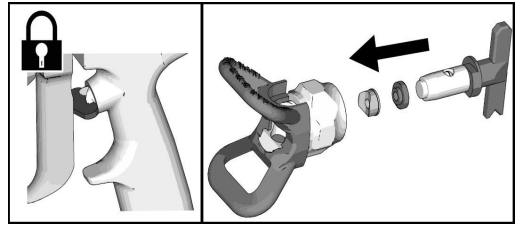

3. Screw assembly onto gun. Hand tighten.

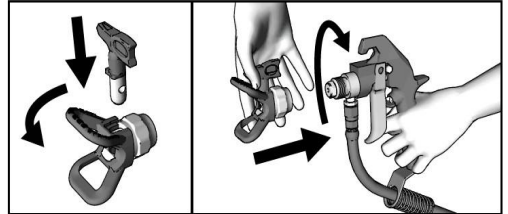

## Gun Placement Install Gun

1. Insert gun into gun holder with hose guard pressed against the holder assembly bracket. Tighten gun into clamp.

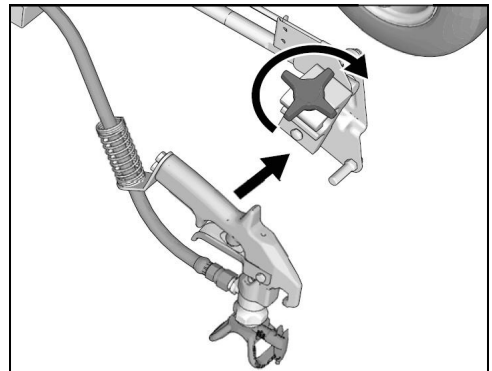

## Position Gun

2. Position gun up/down and forward/reverse.

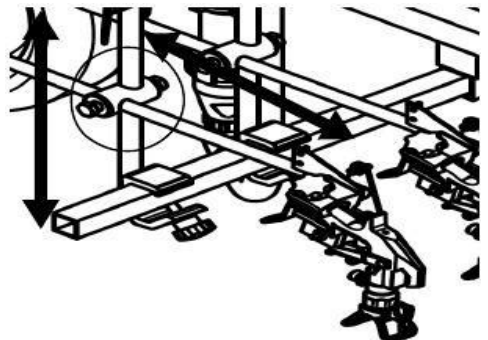

- Position gun left/right.

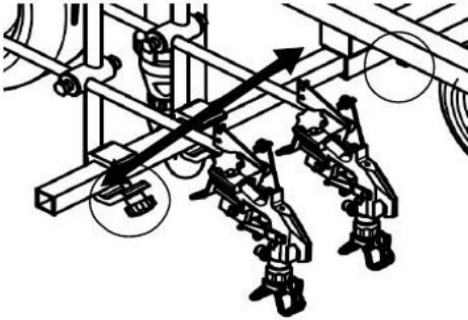

- Right-side gun position:** Place gun and related hardware on right-hand side.

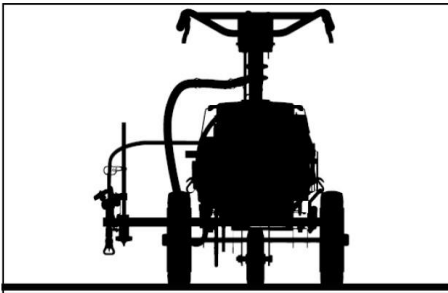

- Left-side gun position:** Place gun and related hardware on left-hand side.

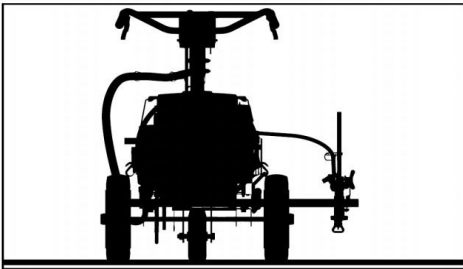

- For **Curb Position**, place gun at 45° angle.

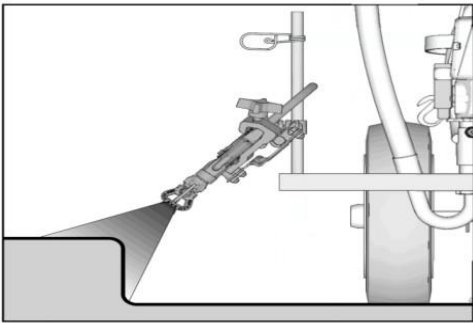

- For **Gun Arc Spray Position**, place gun at rear of striper. Rear position improves arc quality.

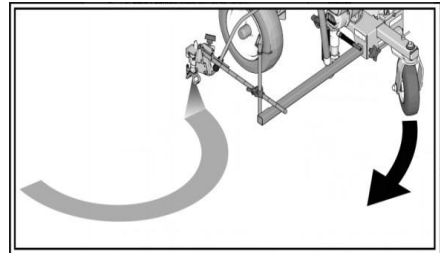

**NOTE:** Verify that the gun can still be triggered **and** that the trigger lock can still be engaged after installation. Make adjustments if necessary.

## Paint Stripe Width

- Adjust gun up or down to change paint stripe width. If desired width can't be attained, change tip.

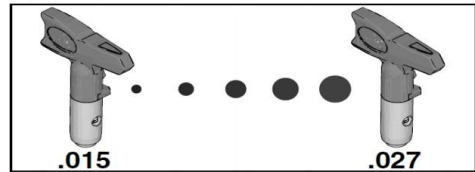
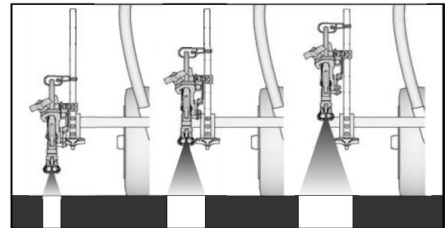

## Spray Test Stripe

- Disengage trigger lock.

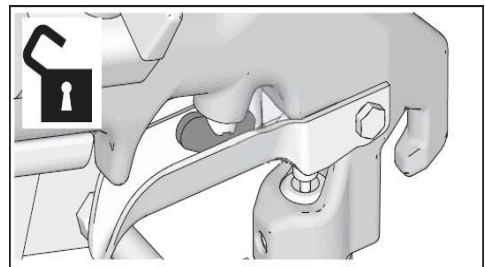

- Trigger gun and spray test pattern. Slowly adjust pressure to eliminate heavy edges. Use smaller tip size if pressure adjustment can not eliminate heavy edges.

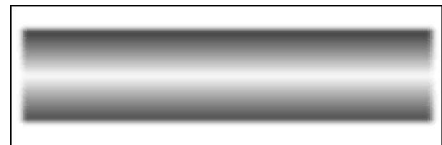

## Clearing Tip Clogs



1. Release trigger. Engage gun trigger lock. Rotate Tip. Disengage gun trigger lock and trigger gun to clear the clog.

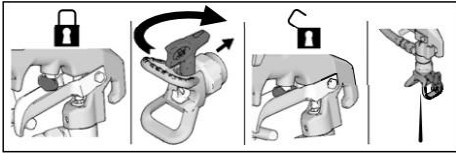

2. Engage gun trigger lock, return Rac Tip to original position, disengage gun trigger lock and continue spraying.

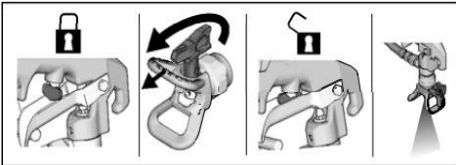

## Clean-up

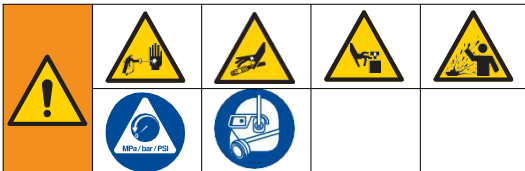

1. Perform Pressure Relief Procedure.  
See **Pressure Relief Procedure**, page 5.
2. Remove Guard and Tip.

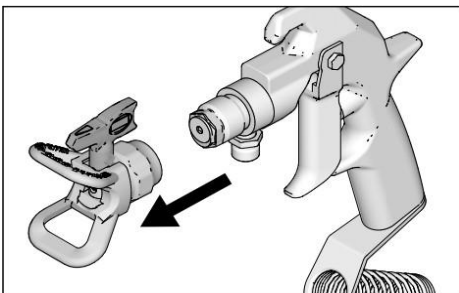

3. Unscrew cap, remove filter. Assemble without filter. Clean filter.

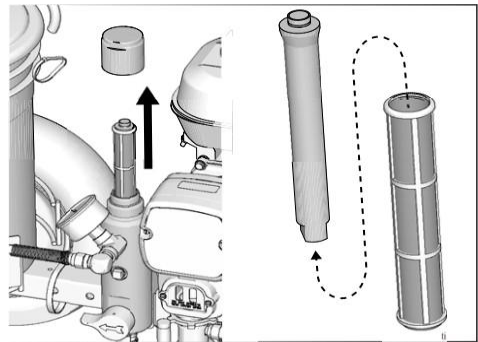

4. Clean gun filter, Guard and Tip in flushing fluid.

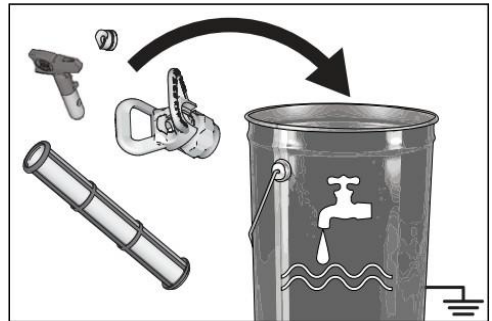

5. Remove siphon tube set from paint and place in flushing fluid. Use water or pump conditioner for water-base paint and mineral spirits for oil-base paint.

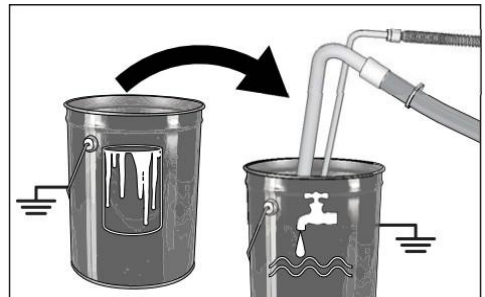

6. Turn engine **ON** . Set pump switch **ON**

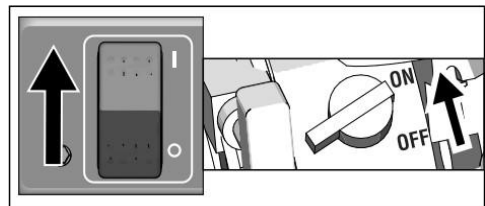

7. Close prime valve.

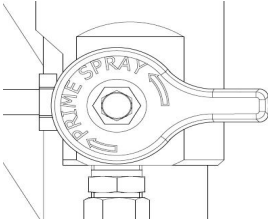

8. Hold gun against paint pail. Disengage gun trigger lock.

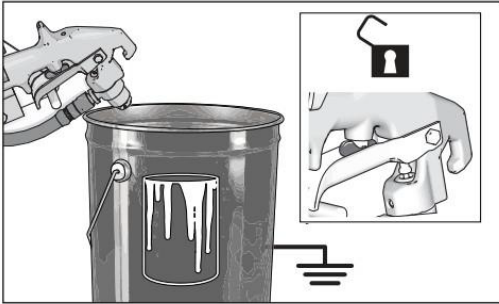

9. Gradually turn pressure control up until motor begins to drive pump. Trigger gun until flushing fluid appears.

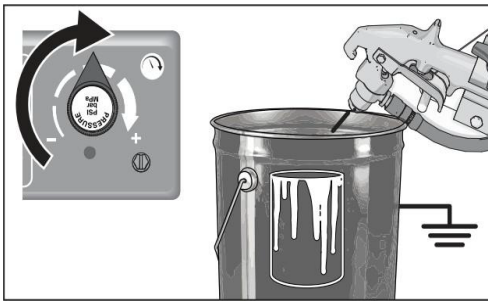

10. Move gun to flushing pail, hold gun against pail, trigger gun to thoroughly flush system. Release trigger and engage trigger lock.

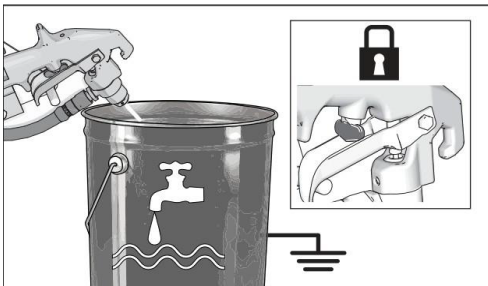

11. Open prime valve and allow flushing fluid to circulate for 20 seconds to clean drain tube.

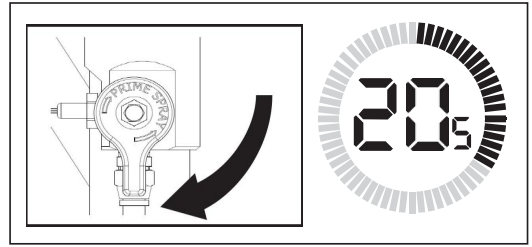

**NOTICE**

Do not run pump without fluid flow. Damage to packings can occur.

12. Raise siphon tube above flushing fluid and run striper for 15 to 30 seconds to drain fluid.

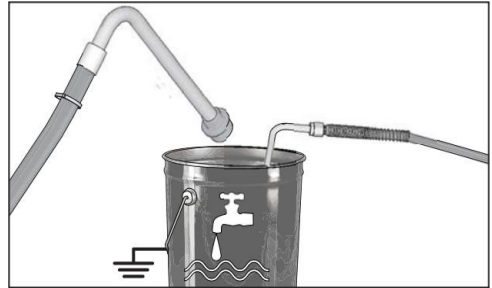

13. Turn pump switch OFF. Turn engine OFF.

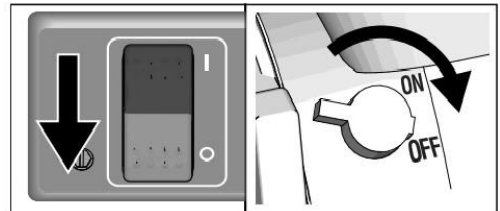

**NOTICE**

If flushing with water, do not leave water in sprayer for extended periods. Flush again with Pump Armor and leave protective coating in the sprayer to prevent freezing or corrosion and to increase sprayer life.



14. Close prime valve. Trigger gun into flushing pail to purge fluid from hose. Open prime valve

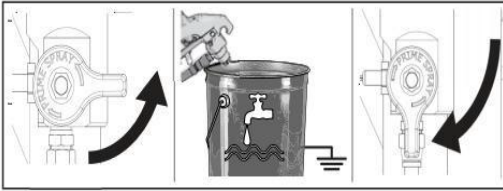

15. Install filter into filter bowl. Make sure plastic center tube is tightened securely.

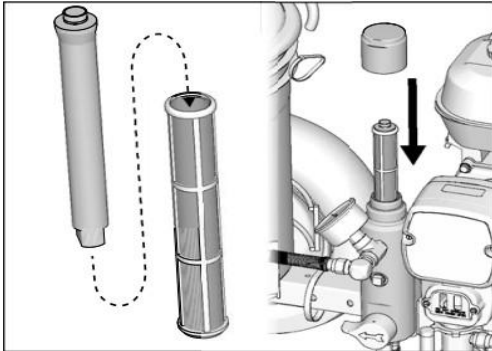

16. Clean Tip, Guard and gasket with a soft bristle brush to prevent part failure due to dried materials. Assemble parts and attach loosely onto gun.

17. Wipe striper, hose and gun with a rag soaked in water or mineral spirits.

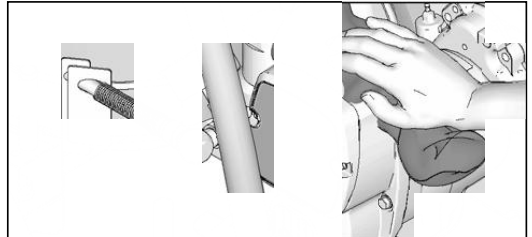

## Flushing Recommendations

If you are going to:	Flush with:	Prime with:	Clean with:	Store with:
Spray with new sprayer or sprayer that has been stored	Compatible solvent such as water or mineral spirits	Compatible paint, such as water-base or oil-base	Compatible solvents such as water or mineral spirits	Mineral spirits
Spray water-base paint	Warm, soapy water, then clean water	Water-base paint	Warm, soapy water, then clean water	Mineral spirits
Spray oil-base paint	Mineral spirits	Oil-base paint	Mineral spirits	Mineral spirits
Change water-base to oil-base paint	Warm, soapy water, then clean water	Mineral spirits	Mineral spirits	Mineral spirits
Change oil-base to water-base paint	Mineral spirits, soapy water, then clean water	Water-base paint	Warm, soapy water, then clean water	Mineral spirits
Change colors, same base	Compatible solvent such as water or mineral spirits			

## Steps to Change Pressure Units

1. Set the potentiometer to the minimum setting.



2. Perform Pressure Relief Procedure (Page 5)  
Ensure the pressure is completely released.

3. Press and hold the button for approximately 3 seconds.

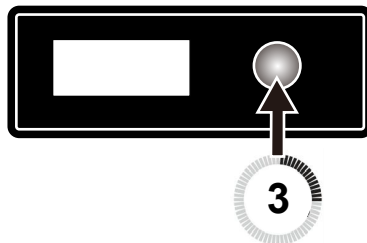

Follow these steps to successfully change the pressure units.

## Marking machine fault alarm description

Display	Description	Alarm Notification	Troubleshooting
E=05	When the clutch engages, if the coil current exceeds a certain value or if there is a severe coil short circuit, it triggers an overcurrent alarm.	Overcurrent Alarm	The overcurrent alarm cannot exit automatically. To resolve the issue, turn off the power and restart after troubleshooting.
POW=H	When the generator voltage exceeds the set maximum power source voltage.	Overvoltage Alarm	Can exit automatically; wait 5 seconds after the power voltage drops below the set maximum power source voltage.
POW=L	When the generator voltage is below the set minimum power source voltage.	Undervoltage Alarm	The undervoltage alarm can exit automatically; wait 5 seconds after the power voltage rises above the set minimum power source voltage.
R=H	When the clutch engages, if the coil resistance exceeds the set value or if there is a coil open circuit.	Over-Resistance Alarm	Cannot exit automatically. Turn off the power and restart after troubleshooting.
R=L	When the clutch engages, if the coil resistance is below the set value or if there is a partial coil short circuit.	Under-Resistance Alarm	Cannot exit automatically. Turn off the power, troubleshoot, and restart.
E=03	When the pressure sensor is damaged or the pressure sensor signal line is not plugged into the socket.	Pressure Sensor Signal Alarm	Can exit automatically; troubleshoot and reinsert the signal line to exit the alarm.
E=02	When the pressure value exceeds a certain value above the set maximum pressure. For example, if the set maximum pressure is 3000 PSI, and the overpressure alarm value is 600 PSI, exceeding 3600 PSI triggers an overpressure alarm.	Overpressure Alarm	Can exit automatically; pressure must drop below the overpressure alarm value to exit the alarm.
EMPTY	When the WD switch is on, in gun-open mode, if the pressure value continuously fails to reach a certain percentage of the potentiometer set pressure for more than 30 seconds. For example, if the potentiometer sets the pressure at 1800 PSI, and the empty bucket ratio is 60%, then 1080 PSI (1800 PSI * 0.6) triggers an empty bucket alarm.	Empty Bucket Alarm	Cannot exit automatically. Turn off the power, troubleshoot, and restart.

# Troubleshooting



Problem	Cause	Solution
Engine will not start	Engine switch is OFF	Turn engine switch ON
	Engine is out of gasoline	Refill gas tank. Honda Engines Owner's Manual.
	Engine oil level is low	Check oil level. Replenish oil, if necessary. Honda Engines Owner's Manual.
	Spark plug is disconnected or damaged	Connect spark plug cable or replace spark plug
	Cold engine	Use choke
	Fuel shutoff lever is OFF	Move lever to ON position
	Oil is seeping into combustion chamber	Remove spark plug. Pull starter 3 to 4 times. Clean or replace spark plug. Start engine. Keep sprayer upright to avoid oil seepage
Engine operates, but displacement pump does not operate	Pump switch is OFF	Turn pump switch ON
	Pressure setting too low	Turn pressure adjusting knob clockwise to increase pressure.
	Fluid filter is dirty	Clean filter. Page 11.
	Tip is clogged	Clean tip. Page 11.
	Displacement pump piston rod is stuck due to dried paint	Repair pump.
	Connecting rod is worn or damaged	Replace connecting rod. Page 18.
	Drive housing is worn or damaged	Replace drive housing. Page 18.
	Electrical power is not energizing clutch field	With pump switch ON and pressure turned to MAXIMUM, use a test light to check for power between clutch test points on control board.  Remove clutch wires from control board and measure resistance across clutch coil. At 70° F, the resistance must be between 1.2+0.2 ohms; if not, replace pinion housing.  Have pressure control checked by authorized dealer.
	Clutch is worn, damaged, or incorrectly positioned	Adjust or replace clutch. Page 19.
	Pinion assembly is worn or damaged	Repair or replace pinion assembly. Page 19

# Displacement Pump Replacement

## Caution

If the pump jam nut loosens during operation, threads of the drive housing will be damaged

## Removal



1. Flush pump.
2. Relieve pressure, page 5.
3. Remove screws(28), slid pump rod shield left(29).

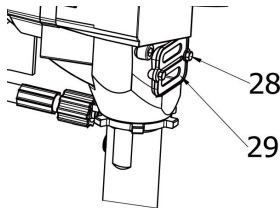

4. Turn slowly pressure control knob clockwise to make motor work slowly until pump pin(44) OFF and unplug power cord. retain ring(43) and push pump pin out.

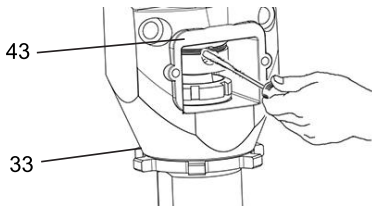

5. Remove the suction tube and hose(32).
6. Loosen pump jam nut(33), unscrew and remove pump.

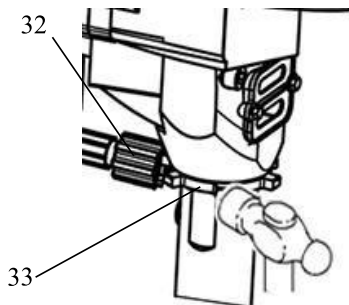

## Installation



If pump pin works loose, parts could break off due to force of pumping action. Parts could project through the air and result in serious injury or property damage.

1. Extend pump piston rod 40mm.
2. Install pump pin. Verify retaining spring is in groove of connecting rod.
3. Push pump up until pump threads engage.
4. Screw in pump until threads are flush with drive housing opening. Align pump outlet to back.

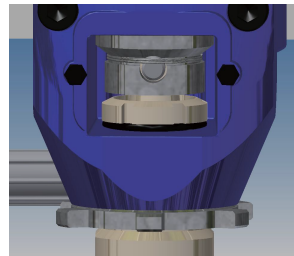

5. Screw jam nut (33) up onto pump until nut stops. Tighten jam nut by hand, then tap 1/8 to 1/4 turn with a 0.5kg (maximum) hammer to approximately 102 Nm.
6. Install pump rod shield (29) with screws (28).
7. Fill packing nut with lubricating oil 5-6 drops.

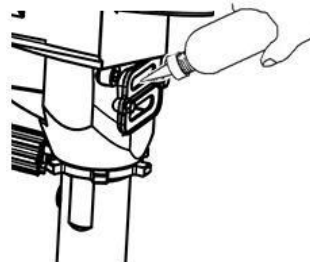

# Drive Housing And Connecting Rod

## Removal



1. Relieve pressure, page 5.
2. Remove screw (2) and front cover (1).
3. Remove screws (28) and pump rod shield (29).
4. Remove pump (34), page 14
5. Remove four screws (4), connecting rod assembly (3) and housing (5)
6. Remove screw (7) and pull drive housing (6) off pinion housing (14).

### CAUTION

Thrust washer may stick to grease inside drive housing. Do not loose or misplace.

7. Check the damage of gear surface and connecting rod (3) in drive housing (6). If need, change them.

## Installation



Make sure gear (6) and thrust washers (8,9,10, 11) are in place (8/10 are copper thrust washers)  
Brush grease onto gear teeth and bearing.

### CAUTION

Do not use drive housing screws to align or seat drive housing with pinion housing. Align these parts with locating pins to avoid premature bearing wear.

1. Push drive housing (6) into pinion housing (14), and fix it with five screws (7). Torque to 21–23 N·m.
2. Install connecting rod (3) and housing (5) to drive housing (6).
3. Install four screws (4). Torque to 21–23 N·m.
4. Install pump (34).
5. Install pump rod shield (29) with screws (28).
6. Install front cover (1) with four screws (2).

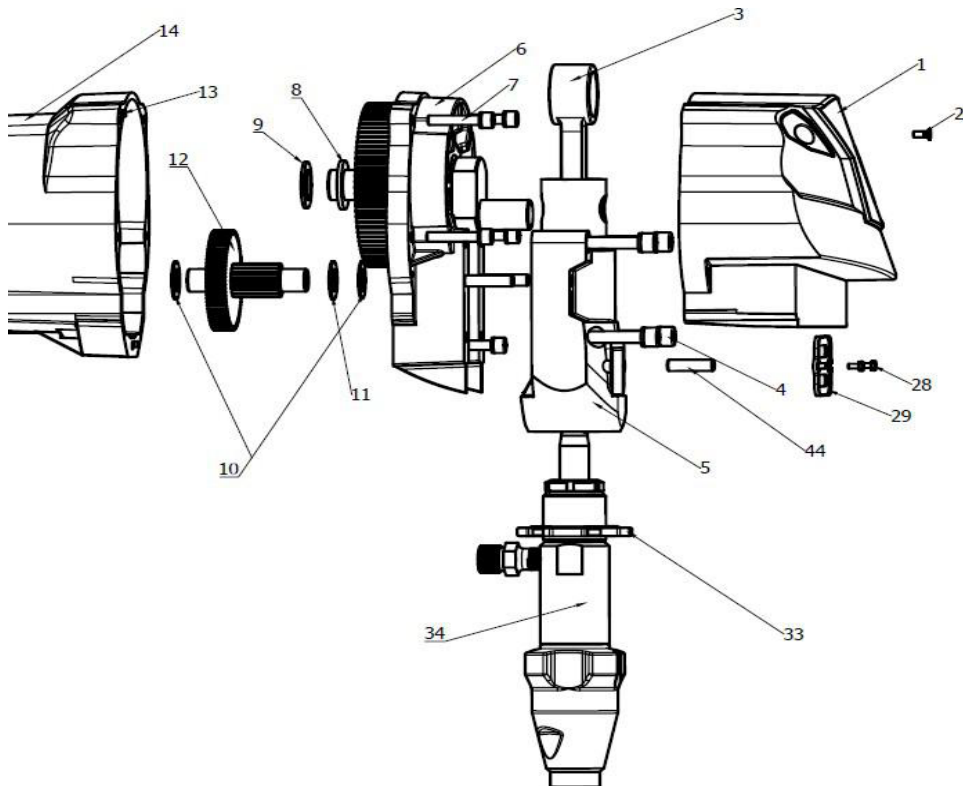

# Pinion Assembly/Clutch

## Removal



1. Perform Pressure Relief Procedure, page 5.
- 2 Remove drive housing, page 18.
3. Disconnect clutch (+) and clutch (-) connectors from wire harness located under sprayer cart.
4. Remove four screws (35) and pinion assembly (14).

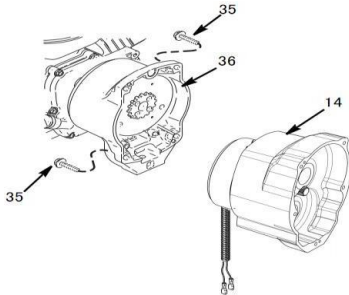

- 5 Place pinion assembly (14) on bench with rotor side up
6. Remove screws (21) and clutch rotor (20).
7. Remove retaining ring (19) and pinion shaft, take out the O-ring (17).
8. Remove screws (16) and clutch coil.

Only replace shaft please skip this step

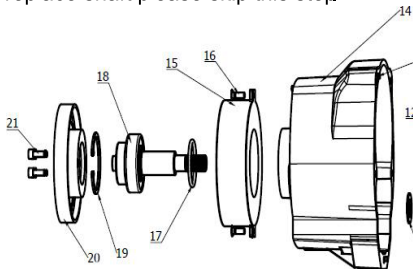

9. Use an impact wrench or wedge something between clutch armature (39) and clutch housing to hold engine shaft during removal
10. Remove four screws (37)
11. Remove clutch armature (39).

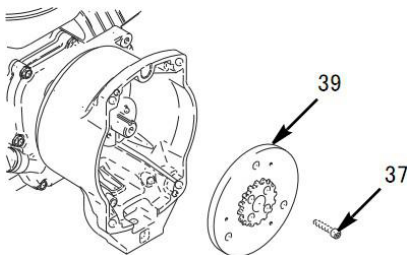

# Clutch

## Installation



1. Lay two stacks of two dimes on smooth bench surface.
2. Lay armature (39) on two stacks of dimes.
3. Press center of hub down to bench surface.

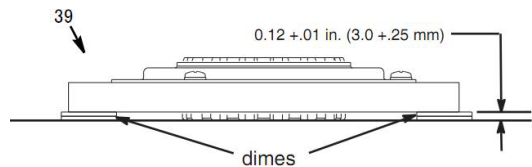

4. Install armature (39) on engine drive shaft.
5. Install four screws (37) with torque of 21-23 Nm.

# Pinion Shaft

## Installation



Brush grease onto gear teeth and bearing.

### CAUTION

Do not use drive housing screws to align or seat drive housing with pinion housing. Align these parts with locating pins, to avoid premature bearing wear.

1. Install clutch coil (15) into pinion assembly.
2. Install o-ring (17).
3. Tap pinion shaft (18) in with plastic mallet.
4. Install retaining ring (19).
5. Place pinion assembly on bench with rotor side up.
6. Apply loctite to screws. Install four screws (21), alternately torque screws to 21-23 Nm until rotor is secure.
7. Install pinion assembly (14) with four screws (35) into clutch housing.
8. Connect clutch (+) and clutch (-) connectors to wire harness.

## Clamp Removal



1. Perform Pressure Relief Procedure, page 5.
2. Remove engine. See Engine Removal, page 21.
3. Drain gasoline from tank according to Honda manual.
4. Tip engine on side so gas tank is down and air cleaner is up.
5. Loosen two screws (41) on clamp (38),
6. Push screwdriver into slot in clamp (38) and remove clamp.

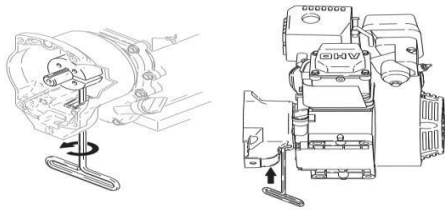

## Clamp Installation



1. Install engine shaft key (37)
2. Tap clamp (38) onto engine shaft (A). Maintain dimension shown note H with rigid, straight steel bar(B).
3. Check dimension: Place rigid, straight steel bar (B) across face of clutch housing (36). Use accurate measuring device to measure distance between bar and face of clamp. Adjust clamp as necessary. Torque two screws (41) to 21-23Nm.

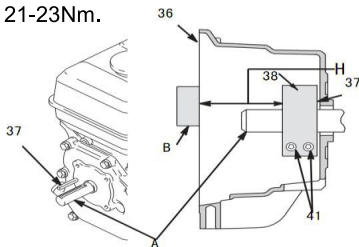

H=(As shown) Measured dimension of pinion assembly C + Measured dimension of clutch rotor D+(0-0.5mm)

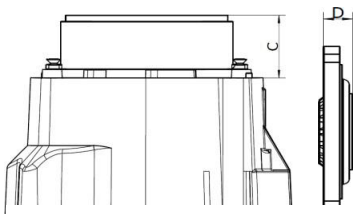

## Clutch Housing Removal

### Removal



1. Remove clamp, page 20.
2. Remove four screws (51) and lock washers (50) which hold clutch housing (36) to engine.
3. Remove screw (145) from under mounting plate.

## Clutch Housing Installation



1. Push on clutch housing (36), make it in right position
2. Install four capscrews (51) and lock washers (50) and secure clutch housing (36) to engine. Torque to 21-23 Nm.
3. Install screw (145) from beneath mounting plate. Torque to 21-23Nm.

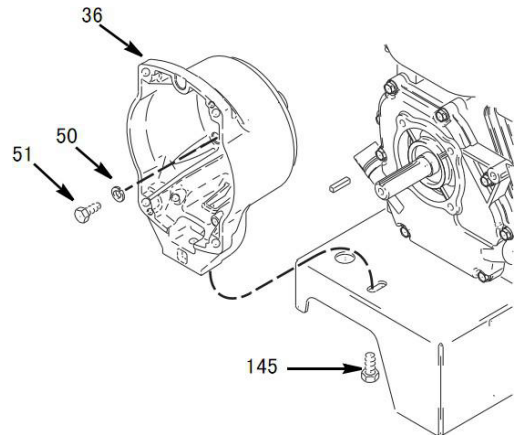

# ENGINE

## Removal



NOTE: All service to the engine must be performed by an authorized Honda dealer.

1. Remove Pinion Assembly/Clutch Armature/Clamp and Clutch Housing as instructed on pages 19 and 20.
2. Disconnect all necessary wiring.
3. Remove two locknuts (111) and screws (110) from base of engine
4. Lift engine carefully and place on work bench.

# ENGINE

## Installation



1. Lift engine carefully and place on cart.
2. Install two screws (110) in base of engine and secure with lock nuts (111). Tighten with torque 21-23 Nm .
3. Connect all necessary wiring.
4. Install Pinion Assembly/Clutch Armature/Clamp and Clutch Housing, as instructed on pages 17, and 18.

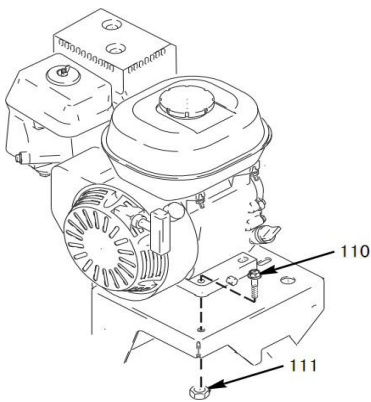

# UPPER RACK

## Installation



1. Fix the upper rack assembly (51) into the rack with two Bolts (52) set.
2. Screw the two nuts (53) into the bolts (52).
3. Secure the upper frame assembly (51) with Four bolts (54).
4. Screw the four nuts (55) into the bolts (54).
5. Tighten the nuts (53), (55), (57). For easy assembling the rack.
6. Insert and tighten the four-pin male connector(59) to the Four-pin female connector(58),which are on the bottom of the Upper rack assembly (51), and the red arrow is the registration position.

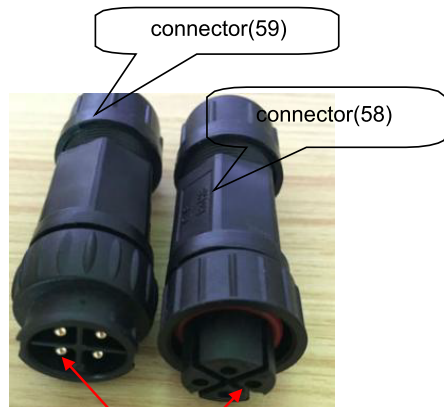
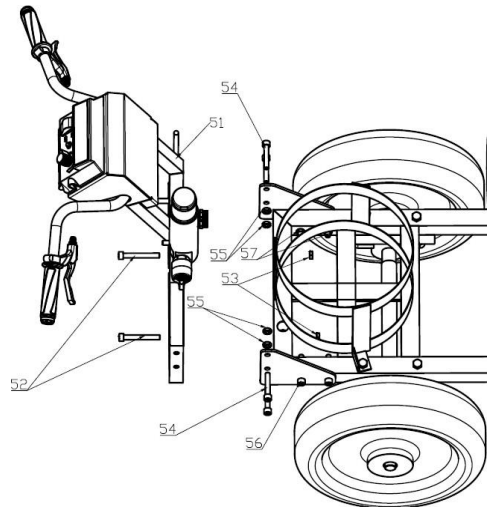

## Technical Data

<b>Road marking machine</b>			
Model Number	<b>HB3400</b>	<b>HB3400II</b>	<b>HB5900</b>
	3600 rpm/min 4.8 HP		
Maximum working pressure	<b>21 MPa, 210 bar</b>		
Maximum delivery	2 7L/min	5L/min	5L/min
Maximum tip size	0.025"	<b>0.017</b>	0.035"
Inlet paint strainer	12 mesh (893 micron)		
Outlet paint strainer	60 mesh (250 micron)		30mesh
Pump inlet size	1 1/4-12 UNF		1 5/16-12 UN
Fluid outlet size	1/4 inches		3/8 inches
Sound power, per ISO 3741	95.4 dBA		
	HONDA Engine GX160		
Wetted parts	stainless steel, PTFE, leather, nylon, zinc-plated and nickel-plated carbon steel, tungsten carbide, chrome plating, UHMWPE, acetal, polyethylene,		
<b>Dimensions</b>			
Gross Weight	97.5kg	<b>115kg</b>	146kg
Package Size	108*67*82cm	<b>108*67*82cm</b>	123*82*84cm
<b>Spray Gun</b>	<b>134A</b>		
Maximum Working Pressure	5400psi / 370bar / 37mpa		
Gross Weight	664g		
Inlet	1/4 npsm male		
Max. material temperature	50°C		

# HB3400

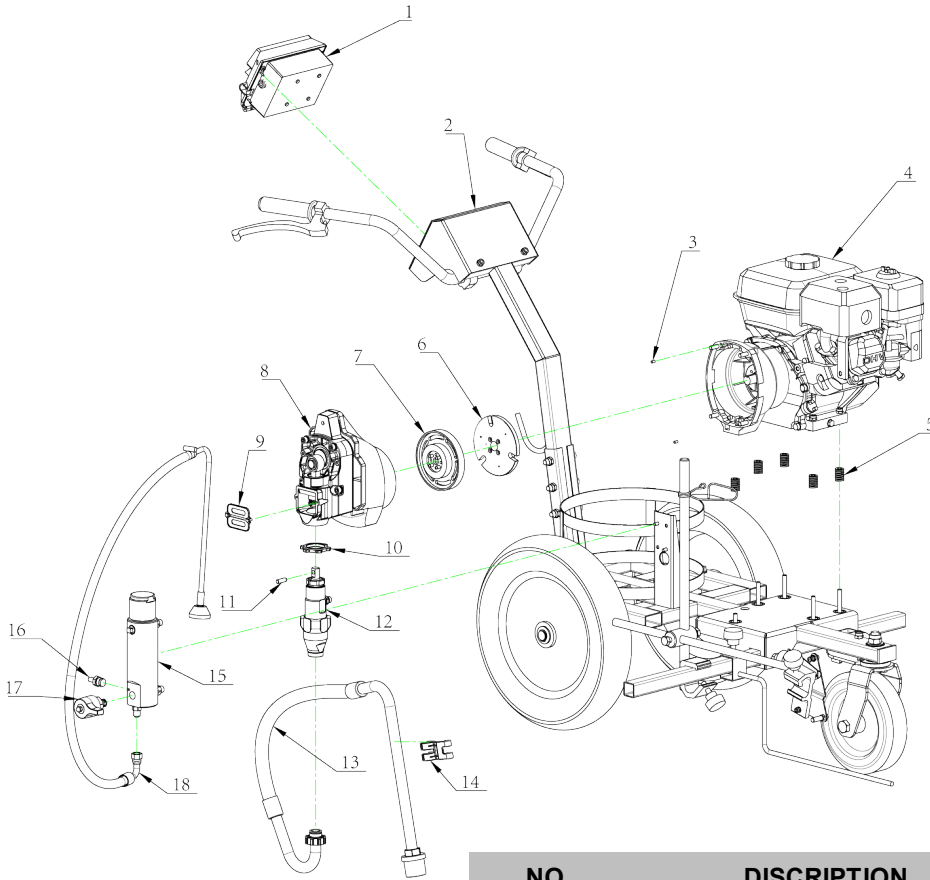

NO	DISCRIPTION	QTY
1	Circuit Board Assembly	1
2	Rack Assembly	1
3	Pin	2
4	GX160 Engine Assembly	1
5	Spring	5
6	Clutch Disc	1
7	Clutch Disc	1
8	Drive Housing Assembly	1
9	Cover	1
10	Nut	1
11	Pin	1
12	Pump Assembly	1
13	Suction House Assembly	1
14	Hook	1
15	Mainfold Assembly	1
16	Pressure Transducer	1
17	Valve	1
18	Return Line Assembly	1

# HB5900

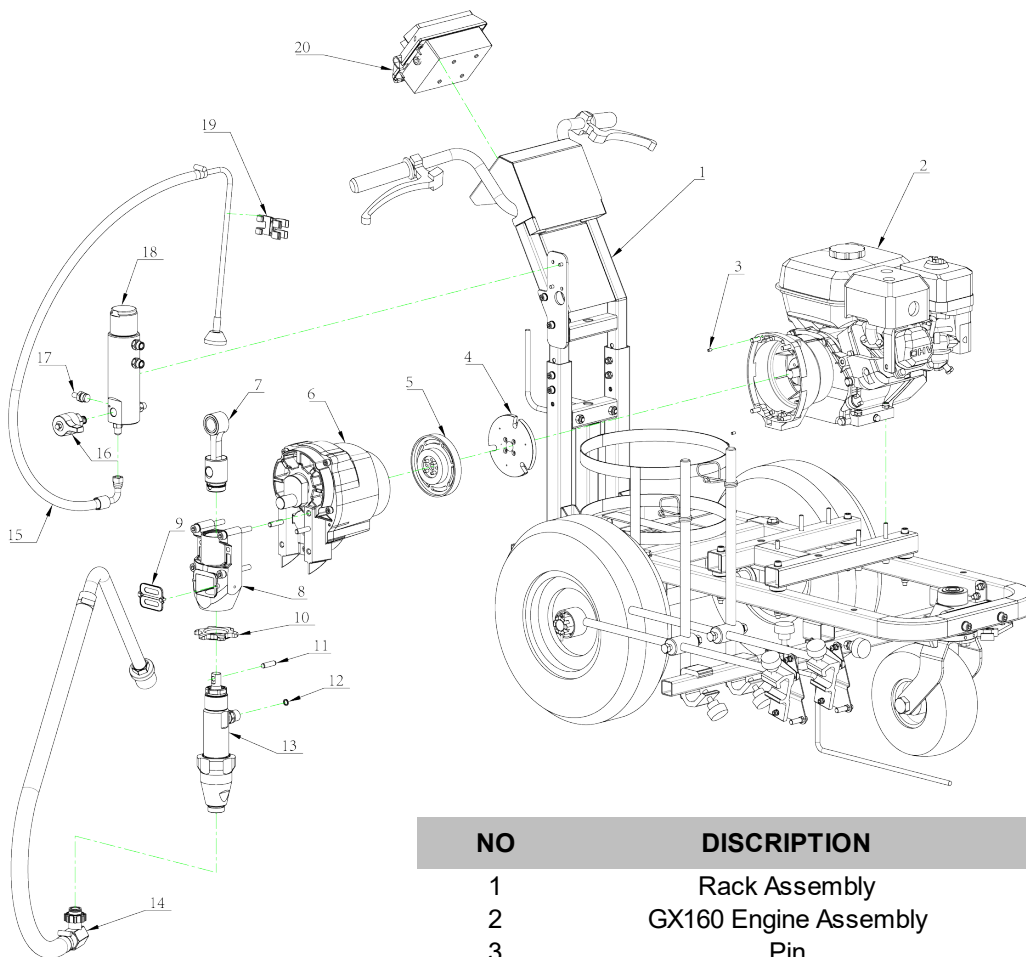

NO	DISCRIPTION	QTY
1	Rack Assembly	1
2	GX160 Engine Assembly	1
3	Pin	2
4	Clutch Disc	1
5	Clutch Disc	1
6	Drive Housing Assembly	1
7	Connecting Rod	1
8	Bearing Housing	1
9	Cover	1
10	Nut	1
11	Pin	1
12	Gasket	1
13	Pump Assembly	1
14	Suction House Assembly	1
15	Return Line Assembly	1
16	Valve	1
17	Pressure Transducer	1
18	Mainfold Assembly	1
19	Hook	1
20	Circuit Board Assembly	1

## HB3400 Pump Assembly

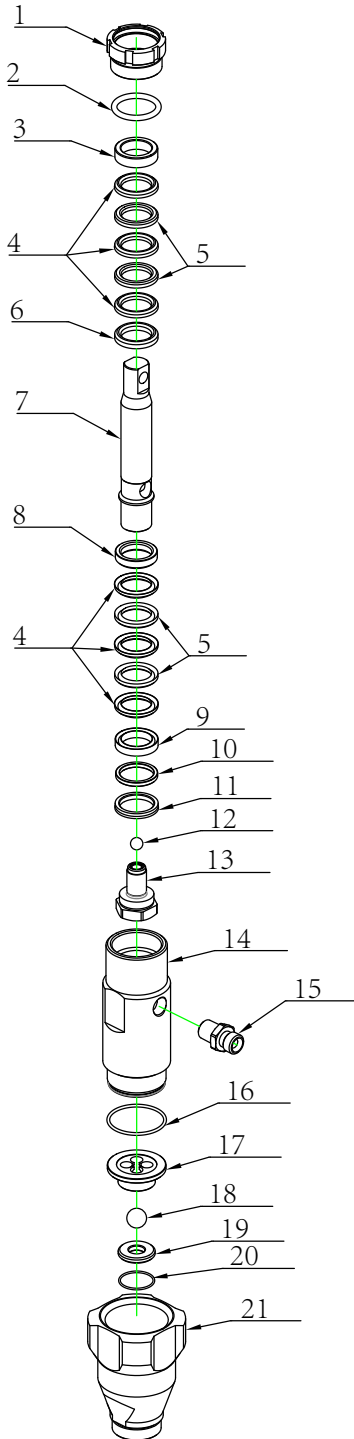

NO	DISCRIPTION	QTY
1	Compression Nut	1
2	O-Ring	1
3	Gland	1
4	V-Packing(Teflon)	6
5	V-Packing(Leather)	4
6	Gland	1
7	Displacement Rod	1
8	Gland	1
9	Gland	1
10	Washer	1
11	Seal	1
12	Ball	1
13	Piston	1
14	Sleeve	1
15	Nipple	1
16	O-Ring	1
17	Ball Retainer	1
18	Ball	1
19	Valve	1
20	O-Ring	1
21	Intake-Housing	1

## HB5900 Pump Assembly

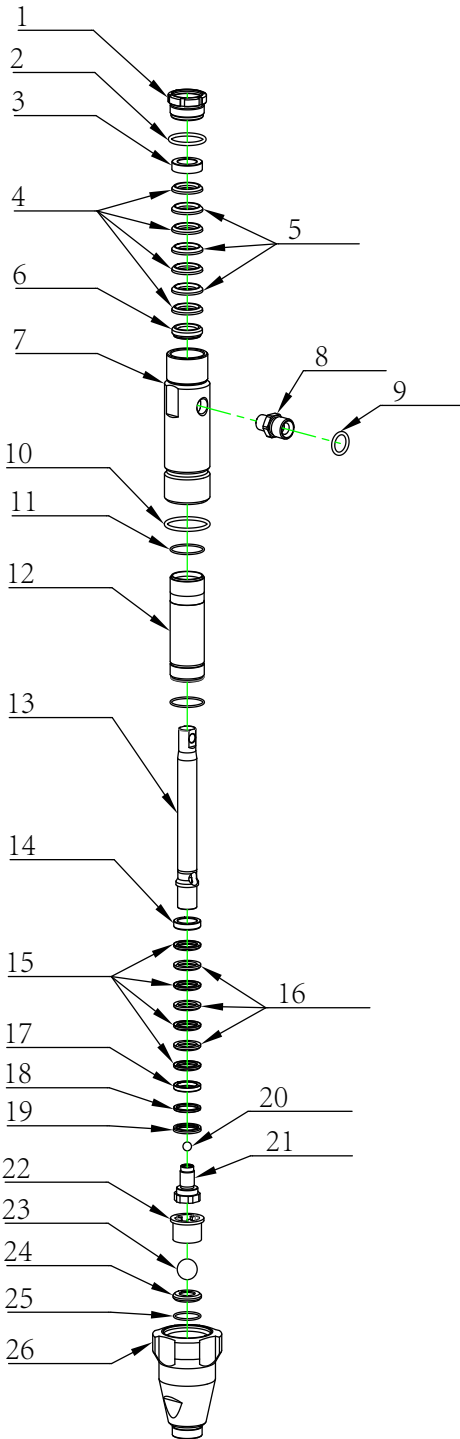

NO	DISCRIPTION	QTY
1	Compression Nut	1
2	O-Ring	1
3	Gland	1
4	V-Packing(Teflon)	4
5	V-Packing(Leather)	3
6	Gland	1
7	Sleeve	1
8	Nipple	1
9	O-Ring	1
10	O-Ring	1
11	O-Ring	2
12	Sleeve	1
13	Displacement Rod	1
14	Gland	1
15	V-Packing(Teflon)	4
16	V-Packing(Leather)	3
17	Gland	1
18	Washer	1
19	Seal	1
20	Ball	1
21	Piston	1
22	Ball Retainer	1
23	Ball	1
24	Valve	1
25	O-Ring	1
26	Intake-Housing	1

## Manifold Filter Assembly

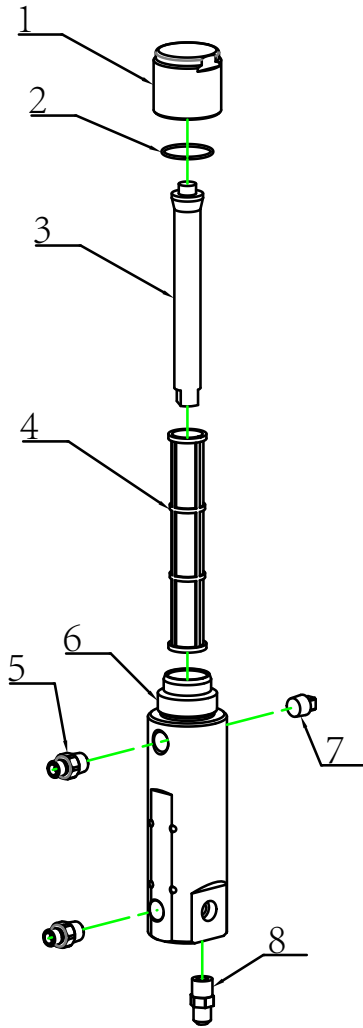

NO	DISCRIPTION	QTY
1	Filter Cap	1
2	O-Ring	1
3	Filter Element	1
4	Filter	1
5	Nipple	1
6	Filter Base	1
7	Plug	1
8	Nipple	1

# Warranty and Limitations

## Warranty General

HVBAN products have a one year guarantee from the invoice date, unless otherwise stated in writing. The warranty covers all manufacturing faults and material defects. Any spare part replacement or repair operations are covered only if they are carried out by our authorized distributors. This warranty covers when the equipment is installed, operated and maintained in accordance with HVBAN written recommendations. HVBAN shall not be liable for, any malfunction, damage or wear caused by faulty installation, misapplication, abrasion, corrosion, inadequate or improper maintenance, negligence, accident, tampering, or substitution of Non-HVBAN component parts. This warranty is conditioned upon the CARRIAGE PAID return of the equipment claimed to be defective to an authorized HVBAN distributors for verification of the claim. If the claimed defect is verified, HVBAN will repair or replace free of charge any defective parts. This components will be returned to the original purchase CARRIAGE PAID If inspection of the equipment does not disclose any defect in material or workmanship, repairs will be made at a reasonable charge, which charges may include the costs of parts, labor, and transportation.

## The Warranty does not cover

- Damage or breakdown caused by improper use or assembly.
- Damage or breakdown caused by the use of spare parts that are different from the original or recommended ones.
- Damage or breakdown caused by bad preservation.
- **Components subject to wear(described in parts list)**

### Warranty Forfeiture:

- In case of delayed payment or other contractual defaults.
- Whenever changes or repairs are carried out on our equipment without prior authorization.
- When the serial number is damaged or removed.
- When the damage is caused by improper use or functioning, or if the equipment falls, is bumped or by other causes not due to the normal working conditions.
- Whenever the unit disassembled, tampered with or repaired without the authorization of HVBAN.



<b>Problem</b>	<b>Cause</b>	<b>Solution</b>
Pump output is low	Strainer is clogged	Clean strainer.
	Piston ball is not seating	Service piston ball.
	Piston packings are worn or damaged	Replace packings.
	O-ring in pump is worn or damaged	Replace o-ring.
	Intake valve ball is not seating properly	Clean intake valve.
	Intake valve ball is packed with material	Clean intake valve.
	Engine speed is too low	Increase throttle setting.
	Clutch is worn or damaged	Adjust or replace clutch. Page 19.
	Pressure setting is too low	Increase pressure.
	Fluid filter or tip is clogged or dirty	Clean filter or clear tip.
	Large pressure drop in hose with heavy materials	Use larger diameter hose and/or reduce overall length of hose. Use of more than 100 ft of 1/4 in. hose significantly reduces performance of sprayer. Use 3/8 in. hose for optimum performance (50 ft minimum).
Excessive paint leakage into throat packing nut	Throat packing nut is loose	Remove throat packing nut spacer. Tighten throat packing nut just enough to stop leakage.
	Throat packings are worn or damaged	Replace packings.
	Displacement rod is worn or damaged	Replace rod.
Fluid is spitting from gun	Air in pump or hose	Check and tighten all fluid connections. Reprime pump.
	Tip is partially clogged	Clear tip. Page 11.
	Fluid supply is low or empty	Refill fluid supply. Prime pump. Check fluid supply often to prevent running pump dry.
Pump is difficult to prime	Air in pump or hose	Check and tighten all fluid connections.  Reduce engine speed and cycle pump as slowly as possible during priming.
	Intake valve is leaking	Clean intake valve. Be sure ball seat is not nicked or worn and that ball seats well. Reassemble valve.
	Pump packings are worn	Replace pump packings.
	Paint is too thick	Thin the paint according to the supplier's recommendations
Clutch squeaks each time clutch engages	Clutch surfaces are not matched to each other when new and may cause noise	Clutch surfaces need to wear into each other. Noise will dissipate after a day of run time.
High engine speed at no load	Misadjusted throttle setting	Reset throttle to 3300 engine rpm at no load
	Worn engine governor	Replace or service engine governor

# Earthing Procedure

-For the application of flammable materials only

				
Keep equipment earth ground to prevent static sparking. Static sparking can cause ignite or explode.				

1. Positioned equipment to prevent tire to the ground.
2. Attach sprayer grounding clamp to metal post connected to earth ground.

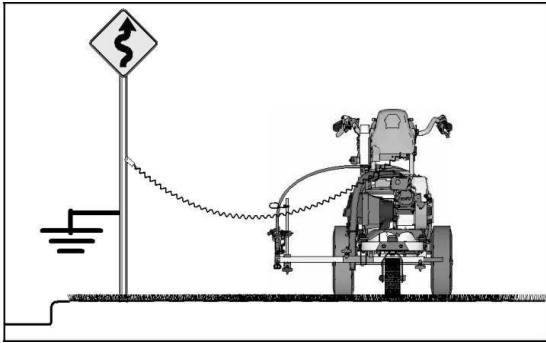

Do not put the metal pail in a wood or something noncond

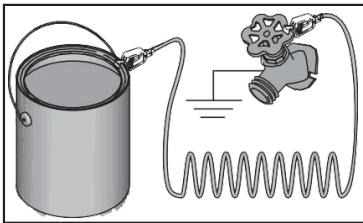



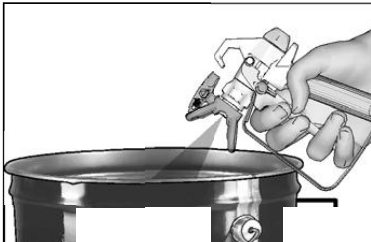



Attached ground wire to pail and true earth ground



Keep grounding when clean up and pressure relief.

# Pressure Relief Procedure

				
				

Equipment is in pressurized state before manually relief. To prevent high-pressure fluid (skin injection, fluid spray, moving parts) cause serious injury. Before checking, moving, or servicing equipment follow the Pressure Relief Procedure in this manual

1. Follow earthing procedure if use flammable materials.
2. Turn power switch OFF and close engine.

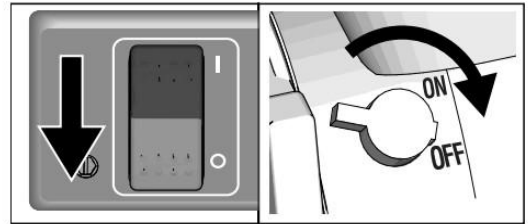

3. Engage gun trigger lock and turn prime valve down.

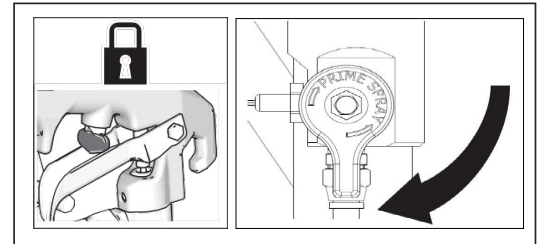

4. If you suspect the spray tip or hose is clogged or that pressure has not been fully relieved after following the steps below

- a. VERY SLOWLY loosen tip guard retaining nut or hose end coupling to relieve pressure gradually.
- b. Then loosen completely.
- c. Clear hose or tip obstruction.



**福州慧邦机械设备有限公司**

**FUZHOU HVBAN MECHANICAL EQUIPMENTS Co., Ltd.**

**HVBAN®**

地址/ADD. : 福州市马尾区马尾镇快洲路56号联东U谷.马尾科创中心2号厂房  
No. 2 Plant, Mawei Sci-Tech Innovation Center, No. 56 Kuaizhou Road Liando U Valley,  
Mawei Town, Mawei District, Fuzhou, Fujian, China

电话/TEL. : **86-591-87913317**      传真/FAX. : **86-591-88067287**

网址/WEB. : **www.hvbansprayer.com**      **www.airless-sprayer.com**

邮箱/E-mail: **hb@airless-sprayer.com**      **hb@fzhbgs.com**